

CATALOG 300

REALI-SLIM[®]

Ball & Roller Bearings



TURNING IDEAS INTO ENGINEERED SOLUTIONS



Create space, save weight.



Now Includes REALI-SLIM TT[™] series turntable bearings.

*New & Improved
Dynamic Capacities!*



An engineering & product selection guide for thin-section bearings

www.kaydonbearings.com

REALI-SLIM® — The Industry Leader in Thin-Section Bearings

When your design calls for thin-section bearings, call KAYDON, the world's leading manufacturer. Our REALI-SLIM® thin-section bearings are designed to create space, save weight, reduce friction, and provide excellent running accuracy. That lets you downsize your design and cut manufacturing costs without sacrificing bearing life or performance.

This latest Catalog 300 makes it easier than ever to find the right thin-section bearing for your application. Choose from our wide range of popular cross-sections and bore sizes (up to 40") or specify a custom design.

What's New:

- **Longer Bearing Life** – Dynamic capacity ratings have been raised for virtually every bearing, often doubling or tripling the bearing life! For our Type X bearings, the ratings improvements range from 31% to 77%, while Type C and Type A bearings are now rated up to 33% higher. These ratings are not just theoretical computations, like those cited by other manufacturers... they have been proven in exhaustive testing. (See Section 3.)

- **REALI-SLIM® Turntable Bearings** – Our custom REALI-SLIM TT™ series thin-section bearings are now part of this catalog. This new series withstands harsh operating environments and provides compact design, greater accuracy, faster and easier installation, and custom configurations to meet your specific application needs. These are ideal for demanding applications like robotics and radar antennae.
- **New Sizes** – 4 new REALI-SLIM® thin-section bearings and 3 new stainless steel REALI-SLIM® bearings are now available with fast delivery to give you even more design options.
- **Improved RFP Form** – The Request For Bearing Proposal Data Form in the back of the catalog lets you provide more application information, so we can get you answers faster. And the form is now perforated for easy removal.

We hope you will find the new Catalog 300 even more useful than previous editions. More technical data can be found at our website (see below). Also, the expert design and applications engineering staff at KAYDON is always available for customer support.

Greater Dynamic Capacity Means Longer Bearing Life

Increase in L₁₀ Dynamic Capacity

100% 125% 150% 175%

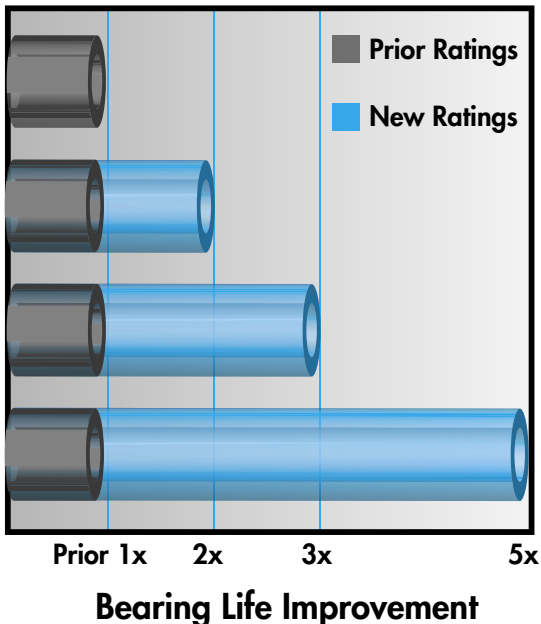

For latest releases — catalog, software, or CAD drawing downloads — visit our website www.kaydonbearings.com.

Table of Contents

	Page Number
Section 1 - Introduction to REALI-SLIM® Thin-Section Bearings	5
• Product Line Overview	
• Specification Control	
• Examples of Design Efficiency	
• Bearing Load Scenarios	
• General Information and Availability Chart	
• General Specifications for Standard Bearings	
• Part Numbering System Explanation	
Section 2 - Selection Tables for Thin-Section Bearings Product Line	14
• Standard Open REALI-SLIM® Inch Series Bearings, AISI 52100: Types A, C, X	
• Sealed REALI-SLIM® Bearings, AISI 52100: Types C, X	
• ENDURAKOTE®-plated ENDURA-SLIM® Bearings	
• Stainless Steel Open REALI-SLIM® Bearings, AISI 440C: Types A, C, X	
• REALI-SLIM MM™ Metric Series Bearings	
• ULTRA-SLIM™ Series Bearings	
• REALI-SLIM TT™ Turntable Series Bearings	
Section 3 - Applications Engineering	65
• Selection Recommendations	
• Capacity, Life, and Load Analysis	
• Mounting Recommendations	
• Precision Classes and Tolerances	
Section 4 - Separator Types, Ball Count, and Performance	92
• Separator Types	
• Number of Balls in Standard Bearings	
• Limiting Speeds	
• Torque	
• Axis Deviations	
• Deflection Curves	
Section 5 - Installation and Maintenance	110
• Inspection and Installation Procedures	
• Lubrication and Maintenance	
Section 6 - Other Products	115
• Metric BB Series Bearings	
• Harsh Environment Bearings	
• KT Series Tapered Roller Bearings	
Section 7 - Appendix and Sales Information	122
• Terms and Definitions	
• Warranty Information and Legal Notices	
• Design Aids and Technical Literature	
• Request for Bearing Proposal Data Form	

The design and application information contained in this catalog is for illustration only. Responsibility for the application of the products contained in this catalog rests solely with the equipment designer or user. In spite of our best efforts, the material contained in this catalog may contain inaccuracies and typographical errors.

REALI-SLIM®... For Compact, Lightweight Designs of the Future.

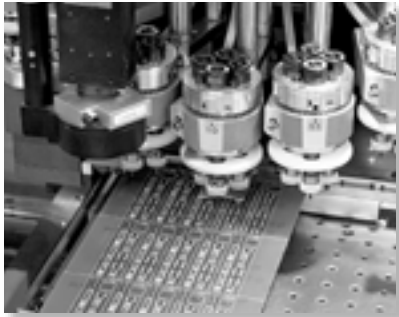

**Semiconductor
Fabrication Equipment**

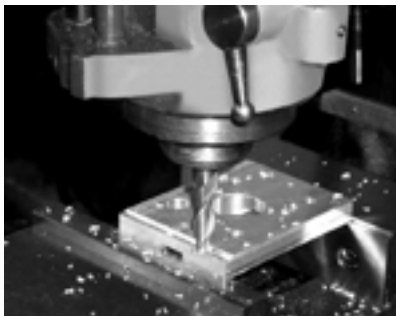

Machine Tools



Rotary Table

- Aerospace and astronomy instrumentation
- Fixturing and workholding equipment
 - Food processing equipment
 - Glassworking equipment
 - Index and rotary tables
 - Packaging equipment
 - Machine tools
 - Medical devices
- Optical scanning equipment
 - Tire making equipment
 - Radar, satellite and communications equipment
 - Robotics
 - Textile machinery
- Tube and pipe cutting machines
- Semiconductor manufacturing equipment
 - Sorting equipment



Radar

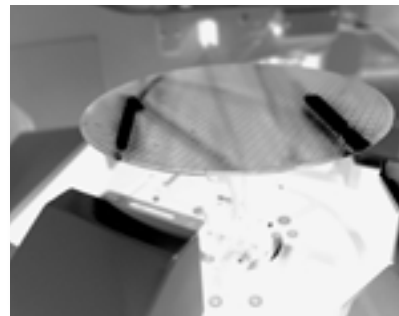

**Robotic Silicon Wafer
Processing**



Textile Printer



Armored Vehicle Sights & FLIRs

KAYDON REALI-SLIM® bearings were designed to fill the need for a fully hardened, thin-section, anti-friction bearing—a need resulting from the modern design concepts of simplicity, miniaturization, weight reduction, and compactness being applied to a wide variety of rotating devices.

Before the introduction of REALI-SLIM® bearings, designers

were forced to use bushings or select bearings from the lightest bearings then commercially available, the standard “Light”, “Extra-Light”, and “Extremely Light” series—many of which often had undesirable cross sections, and excess weight.

REALI-SLIM® bearings overcome the problems of excess weight and size in bearings, shafts, and housings.

Section 1 — An Introduction to REALI-SLIM® Thin-Section Bearings

- **Product Line Overview.....pg.6**
- **Examples of Design Efficiencypg.7**
- **Bearing Load Scenarios..... pgs.8-9**
- **Product Availability Chart.....pg.10**
- **Specifications for Standard Bearingspg.11**
- **Part Numbering System Explanation pgs.12-13**

Product Line Overview

The REALI-SLIM® product line consists of a family of seven open (Figure 1-1) and five sealed (Figure 1-2) series of thin-section bearings ranging in bore diameters from 1.000 inch to 40.000 inches. Series range from .187 x .187 inch to 1.000 x 1.000 inch in cross section. Open bearings are available from stock in three configurations (Types A, C & X). Stock sealed bearings are available in Types C & X only.

We can provide internal fit up, lubricants, separators and other features to meet the most demanding specifications. To obtain corrosion resistance consider using KAYDON stainless steel REALI-SLIM® or ENDURA-SLIM® series of bearings. ENDURAKOTE® plating provides corrosion protection equal to or better than a full AISI 440C stainless steel bearing and can be supplied with very quick delivery.

Additional product line variants include: REALI-SLIM MM™ metric series bearings, ULTRA-SLIM™ bearings, and REALI-SLIM TT™ series turntable bearings (Section 2); and BB metric ball bearings, Harsh Environment bearings, and KT thin-section taper bearings (Section 6).

Within these families, you can generally choose between open bearings for applications where bearings will not be exposed to damaging particulates and sealed bearings for applications where bearings need to be kept clean and well-lubricated.

To support various load scenarios, REALI-SLIM® bearings are

available in three basic types: radial contact (Type C), angular contact (Type A), and four-point contact (Type X)—see pages 8 and 9 for explanations on each type—and in a variety of sizes, or series (e.g., KA, KB, KC, etc.).

REALI-SLIM® bearings are available with various separator options to space the rolling elements uniformly and prevent contact between them. Separator types available include: continuous ring “snap-over pocket”, continuous ring circular pocket, formed wire, toroid, PTFE spacers, and spacer ball separators. See Section 4 for complete details.

SPECIFICATION CONTROL

In today’s world, product traceability is extremely important. To satisfy these requirements, requesting a “specification control drawing” for a REALI-SLIM® bearing is a valuable option to consider.

A specification control drawing provides the user a concise description of the important bearing features and parameters for a specific bearing. A specification control drawing request will generate a unique part number for the standard REALI-SLIM® bearing, including the commercially available options you have selected. This provides the customer quick and easy identification of product in the field as well as a concise receiving and inspection document for the factory.

The Product Line At a Glance

Open Bearings — Figure 1-1

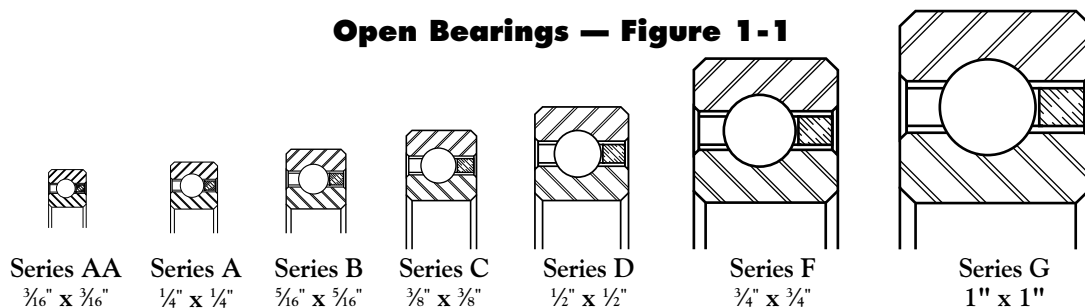

Sealed Bearings — Figure 1-2

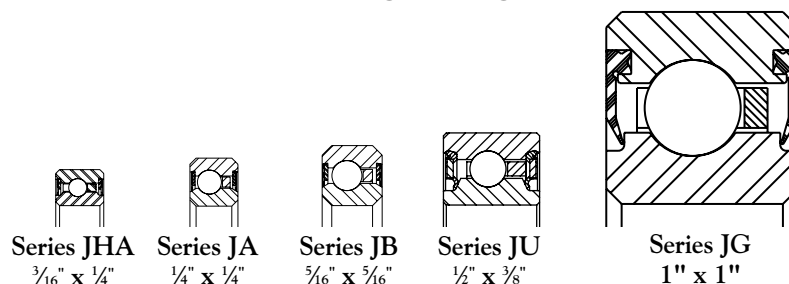

Design Efficiency

REALI-SLIM® Bearings Improve Design Efficiency

In REALI-SLIM® bearings, each series is based on a single cross section which remains constant as the bore diameter is increased. This is in sharp contrast to standard bearings in which the cross section increases as the bore diameter increases. The constant cross section of a REALI-SLIM® bearing is of particular value when designing a product which will be manufactured in various sizes based on shaft diameter and power requirements (Figure 1-3). By using the same series of REALI-SLIM® bearings throughout a product line, the designer can standardize on common components. For all diameters of this rotary table your bearing envelope stays the same.

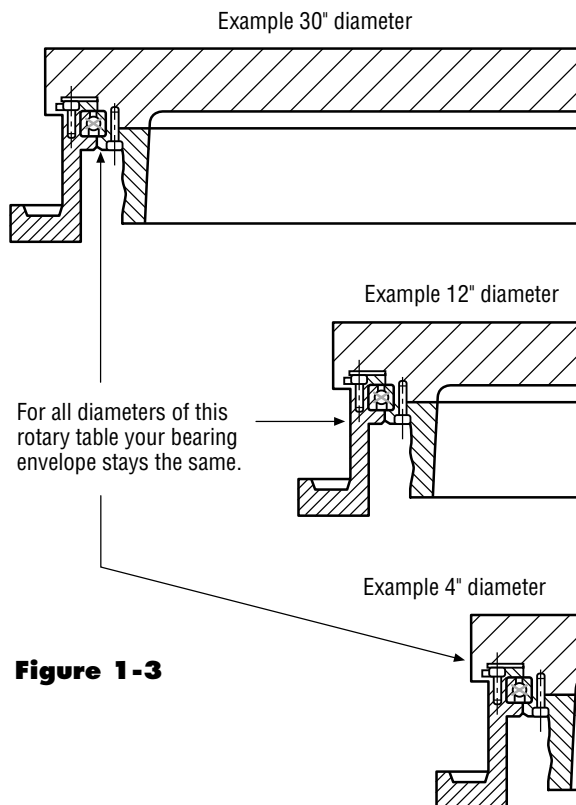

Figure 1-3

REALI-SLIM® Bearings Make a More Compact Design

Additional advantages in application design made possible by REALI-SLIM® bearings can be seen by referring to Figures 1-4, 1-5, and 1-6. A large bore, small cross-section REALI-SLIM® bearing permits the use of a large diameter hollow shaft (Figure 1-5) in place of a smaller diameter solid shaft (Figure 1-4), king-post design. Components such as air and hydraulic lines or electrical wiring and slip rings can then be accommodated within the hollow shaft, resulting in a neater, more efficient design.

In many applications, a single four-point contact REALI-SLIM® bearing (Figure 1-6) can replace two bearings (Figures 1-4 and 1-5) compacting the design and simplifying the bearing mounting. Besides the obvious cost savings of eliminating one bearing, this arrangement also creates space and saves weight. The use of REALI-SLIM® bearings also provides a stiffer structure by using large diameter hollow tubes to replace solid shafts and by supporting the rotating structure (table) at the periphery.

Figure 1-4

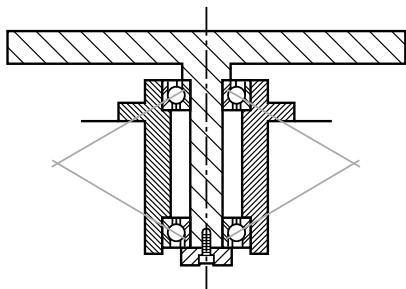

Figure 1-5

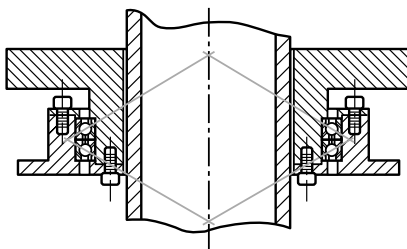
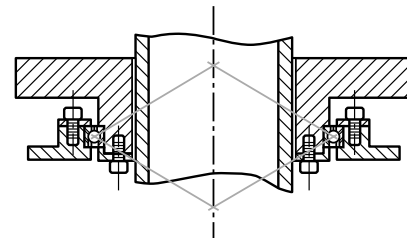

Figure 1-6



REALI-SLIM® Bearing Types Support All Load Scenarios

Radial and Axial (Thrust) Loads

Bearings support a shaft or housing to permit their free motion about an axis of rotation. Load can be applied to bearings in either of two basic directions (Figure 1-7). Radial loads act at right angles to the shaft (bearing's axis of rotation). Axial (thrust) acts parallel to the axis of rotation. When these loads are offset from either the bearing axis (distance S_t) or radial plane (distance S_r), a resulting moment load (M) will be created. KAYDON REALI-SLIM® bearings are available in a variety of types to handle radial loads, axial loads and moment loads.

Figure 1-7

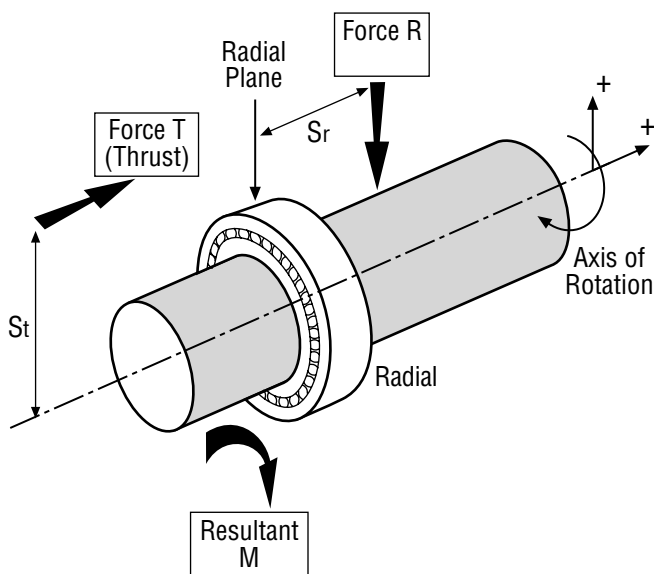

The resultant moment load (M) equation:
 $M = (\pm T) (S_t) + (\pm R) (S_r)$

Types of REALI-SLIM® Bearings

REALI-SLIM® bearings are available in three basic configurations: radial (Type C), angular contact (Type A), and four-point contact (Type X).

REALI-SLIM® Bearing Types
A = angular
C = radial
X = four-point

By using these three types, the customer has a wider choice of mounting arrangements to meet load, stiffness and accuracy requirements in the most efficient manner.

Radial Contact Bearing (Type C)

The Type C Radial Contact Bearing (Figure 1-8) is a single row radial ball bearing of conventional design. It is a Conrad-type assembly, which means that it is assembled by eccentric displacement of the inner race within the outer race which permits insertion of about half of a full complement of balls.

REALI-SLIM® TYPE C

Figure 1-8

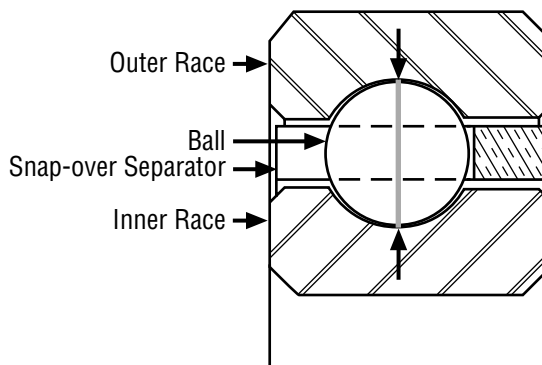

Although the Type C bearing is designed primarily for radial load application, it can be configured to accept some axial (thrust) load in either direction. But, if thrust is a concern, a set of angular contact bearings should be considered for the specific application.

REALI-SLIM® BEARING TYPES SUPPORT ALL LOAD SCENARIOS (continued)**Angular Contact Bearing (Type A)**

The Type A Bearing is also a conventional design. It features a circular pocket separator and a 30° contact angle (see Figure 1-9) along with approximately 67% of a full complement of balls.

The chief benefit of the Type A bearing is that it provides greater thrust capacity than a Type C or Type X bearing. Because of its counterbored outer race, Type A bearings have unidirectional thrust capacity. Thus, this bearing should be mounted opposed to another bearing to establish and maintain the contact angle, and to support reversing thrust loads.

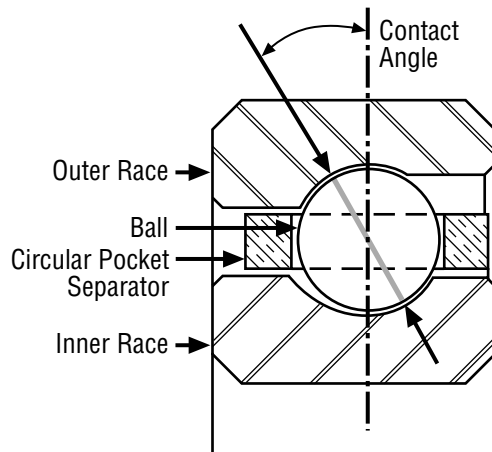
REALI-SLIM® TYPE A**Figure 1-9****Four-Point Contact Bearing (Type X)**

Standard bearing lines are most often designed to handle either radial or axial load conditions. The unique feature about the KAYDON REALI-SLIM® Type X four-point contact bearing line (see Figure 1-10) is that the gothic arch geometry of the inner and outer races enables a single bearing to carry three types of loading (radial, axial and moment) simultaneously. This makes it the bearing of choice for many applications since a single four-point contact bearing can often replace two bearings, providing a simplified design.

Type X bearings may also be furnished with an internal diametral preload for those applications requiring greater stiffness or zero free play. This is accomplished by using balls that are larger than the space provided in the raceways. The balls and raceways, therefore, have some elastic deformation in the absence of an external load.

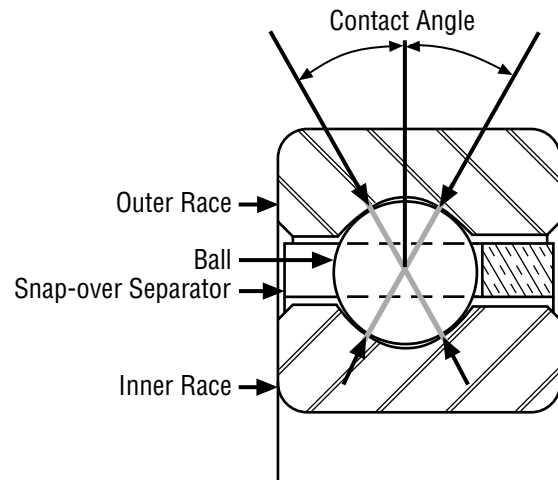
REALI-SLIM® TYPE X**Figure 1-10**

NOTE: KAYDON does not recommend the use of two Type X bearings on a common shaft, as it could result in objectionable friction torque.

General Information and Availability Chart

Standard REALI-SLIM® Bearings—are those listed in the Series Data Tables. They are manufactured to KAYDON Precision Class 1 and the specifications on page 11. New sizes are added to stock periodically and updated on our website. Be sure to visit www.kaydonbearings.com for latest information.

Options

REALI-SLIM® Bearings—can be optimized for your special requirements. Standard commercial options include: changes in diametral clearance, preloading, lubricants, packaging, etching of high points, tagging bearings with actual dimensions as requested, separators, duplexing, data sheets, acceptance testing, etc.

REALI-SLIM® Bearings—with non-standard materials, sizes, tolerances, specifications, and features are available. We will be pleased to quote on your requirements.

Order REALI-SLIM® Bearings—by bearing numbers shown in Series Data Tables.

Assistance—in bearing selection will be furnished by our regional sales managers or the KAYDON Engineering Department upon request.

Changes—KAYDON reserves the right to change specifications and other information included in this catalog without notice.

Figure 1-11

This table applies to AISI 52100 standard bearings. For stainless steel, please see Section 2.

Series	Type	Bore Diameter In Inches																																			
		1	1½	1¾	2	2½	3	3½	4	4¼	4½	4¾	5	5½	6	6½	7	7½	8	9	10	11	12	14	16	18	20	21	22	25	30	35	40				
JHA Series ⅜" Radial Section	A																																				
	C	•	•	•																																	
	X	•	•	•																																	
KAA Series ⅜" Radial Section	A	•	•	•																																	
	C	•	•	•																																	
	X	•	•	•																																	
JA Series ¼" Radial Section	A																																				
	C				•	•	•	•	•	•	•	*	•	*	*	*																					
	X				•	•	•	•	•	•	•	*	•	*	*	*	•																				
KA Series ¼" Radial Section	A				•	•	•	•	•	•	•	•	•	•	•	•	•	•	*	*	•	*	*														
	C				•	•	•	•	•	•	•	•	•	•	•	•	•	•	•	•	•	•	•	•	•	•	•	•	•	•	•	•	•	•	•		
	X				•	•	•	•	•	•	•	•	•	•	•	•	•	•	•	•	•	•	•	•	•	•	•	•	•	•	•	•	•	•	•	•	
JB Series ⅜" Radial Section	A																																				
	C				•	•	•	•	•	•	•	*	*	*	*	*																					
	X				•	•	•	•	•	•	•	*	*	*	*	*	•																				
KB Series ⅜" Radial Section	A				•	•	•	•	•	•	*	*	*	*	*	*	*	*	*	*	*	*	*	*	*	*	*	*	*	*	*	*	*	*	*		
	C				•	•	•	•	•	•	*	*	*	*	*	*	*	*	*	*	*	*	*	*	*	*	*	*	*	*	*	*	*	*	*	*	
	X				•	•	•	•	•	•	*	*	*	*	*	*	*	*	*	*	*	*	*	*	*	*	*	*	*	*	*	*	*	*	*	*	
KC Series ⅜" Radial Section	A								•	*	•	•	•	•	•	•	•	•	•	•	•	•	•	•	•	•	•	•	•	•	•	•	•	•	•		
	C								•	*	•	•	•	•	•	•	•	•	•	•	•	•	•	•	•	•	•	•	•	•	•	•	•	•	•	•	
	X								•	*	•	•	•	•	•	•	•	•	•	•	•	•	•	•	•	•	•	•	•	•	•	•	•	•	•	•	•
JU Series ⅜" Radial Section	A																																				
	C								•	•	•	•	•	•	•	•	•	•	•	•	•	•	•	•	•	•	•	•	•	•	•	•	•	•	•	•	
	X								•	•	•	•	•	•	•	•	•	•	•	•	•	•	•	•	•	•	•	•	•	•	•	•	•	•	•	•	•
KD Series ½" Radial Section	A								•	•	•	•	•	•	•	•	•	•	•	•	•	•	*	*	*	*	*	*	*	*	*	*	*	*	*		
	C								•	•	•	•	•	•	•	•	•	•	•	•	•	•	*	*	*	*	*	*	*	*	*	*	*	*	*	*	
	X								•	•	•	•	•	•	•	•	•	•	•	•	•	•	*	*	*	*	*	*	*	*	*	*	*	*	*	*	
KF Series ¾" Radial Section	A								*	*	*	•	*	•	•	•	•	•	•	•	•	•	•	•	•	•	•	•	•	•	•	•	•	•	•	•	
	C								•	•	*	•	•	•	•	•	•	•	•	•	•	•	•	•	•	•	•	•	•	•	•	•	•	•	•	•	•
	X								•	•	•	•	•	•	•	•	•	•	•	•	•	•	•	•	•	•	•	•	•	•	•	•	•	•	•	•	•
JG Series 1" Radial Section	A																																				
	C																							*	*	*	*	*	*	*	*	*	*	*	*	*	
	X																							*	*	*	*	*	*	*	*	*	*	*	*	*	
KG Series 1" Radial Section	A								*	*	*	*	*	*	*	*	*	*	*	*	*	*	*	*	*	*	*	*	*	*	*	*	*	*	*	*	
	C								*	*	*	*	*	*	*	*	*	*	*	*	*	*	*	*	*	*	*	*	*	*	*	*	*	*	*	*	*
	X								*	*	*	*	*	*	*	*	*	*	*	*	*	*	*	*	*	*	*	*	*	*	*	*	*	*	*	*	*

• Available from stock. * Limited Availability – contact KAYDON for lead time and minimum purchase requirement.

Specifications for Standard REALI-SLIM® Bearings

ITEM	DESCRIPTION	REFERENCE SPECIFICATION
MATERIAL ANALYSIS		
RACES & BALLS	AISI 52100 Type Steel Vacuum Degassed AISI 440C Stainless Steel	ASTM A-295, AMS-STD-66 ASTM A-756
SEPARATORS C, X BEARINGS	P Type—Brass or Non-metallic composite L Type—Nylon, Fiberglass Reinforced	ASTM B-36 or B-134
A BEARINGS	R Type—Brass or Non-metallic composite G Type—Nylon, Fiberglass Reinforced	ASTM B-36 or B-134
SEALS	Nitrile Rubber, 70 Durometer, Steel Reinforced	MIL-R 6855
HEAT TREATMENT		
RACES	Through hardened and dimensionally stabilized for use from -65°F to +250°F (-54°C to +121°C)	
BALLS	AISI 52100—Hardened to Rc 62-66, AISI 440C—to Rc 58-65	
PRECISION		
RACE DIMENSIONS	KAYDON Precision Class 1	ABMA ABEC-1F or better
RACE RUNOUTS	KAYDON Precision Class 1	ABMA ABEC-1F or better
BALLS	ABMA Grade 10	ANSI/ABMA/ISO 3290
DIAMETRAL CLEARANCE AND CONTACT ANGLE		
TYPE C BEARING	Sufficient diametral clearance to provide small amount of running clearance after installation with recommended fits Gothic Arch Form for two 30° contact angles under light radial gaging load. Sufficient diametral clearance to provide clearance after installation with recommended fits Diametral clearance for 30° contact angle in single unmounted bearing under light axial gaging load. Wide range of preload or running clearance for matched sets	ABMA Standard 26.2
TYPE X BEARING		
TYPE A BEARING		
SEPARATOR DESIGN		
P & L TYPES C, X BEARINGS	Circular Ring, Snapped Over Balls for Retention	
R & G TYPES A BEARINGS	Circular Ring, Circular Pockets, Self Retained	
OTHER		
QUALITY CONTROL	KAYDON Quality Control procedures have been approved by major aerospace industries and agencies of the U.S. Government	ISO 9001
IDENTIFICATION	Marked on Bearing O.D.: CAGE Code, "KAYDON"®, Part Number and Date Code	MIL-STD-130
CLEANING	Multiple cycle immersion and agitation in solvents and/or aqueous cleaners	
PRESERVATIVE	Preservative Oil	
PACKAGING	Heat Sealed in Plastic Bag & Boxed	

NOTE—Also available: Quality Control per MIL-Q-9858, Packaging and Lubrication options, and "Clean Room" Facilities.

Identification of REALI-SLIM® Bearings

REALI-SLIM® bearings are marked for complete identification with an (8) or (9) digit part number. Positions 1-8 identify

materials, size, type, and precision. Position 9 (optional) identifies non-standard internal fit.

Part Number Code Example — Figure 1-12

Position	1	2	3	4	5	6	7	8	9	10-13
Nomenclature	Material	Series	Size			Type	Separator	Precision	Internal Fit	DFAR Compliance
Example	K	G	1	2	0	X	P	O	L	-USA

Position 1 - Material

Races/Balls	Seals, Shields
A AISI 52100 Steel	with One seal—PTFE
B AISI 52100 Steel	with Two seals—PTFE
D AISI 52100 Steel	with One shield
E AISI 52100 Steel	with Two shields
F AISI 52100 Steel	with One seal—Nitrile rubber LAMI-SEAL®
G AISI 52100 Steel	with Two seals—Nitrile rubber LAMI-SEAL®
H AISI 52100 Steel	with One seal—Nitrile rubber
J AISI 52100 Steel	with Two seals—Nitrile rubber
K AISI 52100 Steel	with No seals or shields
L AISI 52100 Steel	with Two seals and ENDURAKOTE® plating
M M-50 Steel	with No seals or shields
N AISI 52100 Steel	with No seals and ENDURAKOTE® plating
P AISI 17-4PH Steel	with Ceramic Balls (see Section 6)
Q AISI 52100 Steel	with No shields or seals
S AISI 440C Stainless Steel	with No seals or shields
T AISI 440C Stainless Steel	with One seal—PTFE
U AISI 440C Stainless Steel	with Two seals—PTFE
V AISI 440C Stainless Steel	with Two shields
W AISI 440C Stainless Steel	with Two seals—Nitrile rubber
X AISI 52100 Steel	with Ceramic Balls
Y AISI 440C Stainless Steel	with Ceramic Balls (see Section 6)
Z	Other

Position 2 - Series Cross Section

	Radial Thickness	Width	
Standard Cross-Sections	A	*.187 x .187	
	or	.250 x .250	
	B	.312 x .312	
	C	.375 x .375	
	D	.500 x .500	
	E	.625 x .625	
	F	.750 x .750	
	G	1.000 x 1.000	
	Extended Width	H	*.187 x .250
		or	.250 x .312
		I	.312 x .375
J		.375 x .437	
K		.500 x .578	
Extra-Extended Width	L	.625 x .727	
	M	.750 x .875	
	N	1.000 x 1.187	
	S	*.187 x .312	
	or	.250 x .375	
	T	.312 x .437	
	U	.375 x .500	
	V	.500 x .656	
	W	.625 x .828	
	X	.750 x 1.000	
	Y	1.000 x 1.375	

*Smaller section applies when position 3 is alphabetic—see following explanations of positions 3, 4, and 5.

IDENTIFICATION OF REALI-SLIM® BEARINGS (continued)**Position 3, 4 and 5—Size (Bearing Bore)****Numeric Characters**

Nominal bearing bore in inches multiplied by ten

Alphabetic Characters

“A” In Position 3 in combination with “A” in Position 2 denotes .187 x .187 Series

“A” In Position 3 in combination with “H” in Position 2 denotes .187 x .250 Series

“A” In Position 3 in combination with “S” in Position 2 denotes .187 x .312 Series

Examples

040 = 4.0" Bore

120 = 12.0" Bore

400 = 40.0" Bore

“10” following “AA” in Positions 2 & 3 = .187 x .187 Series with 1.0" Bore

“15” following “HA” in Positions 2 & 3 = .187 x .250 Series with 1.5" Bore

Position 6—Bearing Type (see Section 3)

- A Angular contact single bearing (not ground for universal duplexing)
- B Angular contact pair—duplexed back to back
- C Radial contact
- F Angular contact pair—duplexed face to face
- T Angular contact pair—duplexed tandem
- U Angular contact single bearing—ground for universal duplexing
- X Four-point contact
- Z Other

Position 7—Separator (see Section 4)

- C Non-metallic composite, segmental, “snap-over” type
- D Phenolic laminate, one-piece ring “snap-over” type
- E Brass, segmental “snap-over” type
- F Full complement bearing—no separator
- G Nylon one-piece ring, circular pocket
- H Phenolic laminate, one-piece ring with circular pockets
- J Nylon strip separator, circular pockets
- K Phenolic laminate, riveted two-piece ring
- L Nylon, one-piece ring “snap-over” type
- M Formed wire, strip or segmental, “snap-over” type, ball in every pocket
- N Nylon, “snap-over” type
- P Standard formed ring “snap-over” type (material—brass or non-metallic composite)
- Q PEEK, one-piece ring, circular pocket
- R Standard formed ring, circular pocket (material—brass or non-metallic composite)
- S Helical coil springs
- T Stainless steel, formed ring “snap-over” type
- U Stainless steel, formed ring circular pockets

- V Brass, formed ring, “snap-over” type
- W Formed wire, strip or segmental, “snap-over” type
- X PEEK, one-piece, “snap-over” pocket
- Y Brass, formed ring, circular pockets
- Z Other (toroids, slugs, spacer balls or others available)

Position 8—Precision (see Section 3)

(ABEC Specifications are per ABMA Standard 26.2)

- 0 KAYDON Precision Class 1 per ABEC 1F
- 1 KAYDON Precision Class 1 with Class 4 Runouts
- 2 KAYDON Precision Class 1 with Class 6 Runouts
- 3 KAYDON Precision Class 3 per ABEC 3F
- 4 KAYDON Precision Class 4 per ABEC 5F
- 6 KAYDON Precision Class 6 per ABEC 7F
- 8 Other

Position 9—Bearing Internal Fit

- A .0000 to .0005 Clearance
- B .0000 to .0010 Clearance
- C .0005 to .0010 Clearance
- D .0005 to .0015 Clearance
- E .0010 to .0020 Clearance
- F .0015 to .0025 Clearance
- G .0020 to .0030 Clearance
- H .0030 to .0040 Clearance
- I .0040 to .0050 Clearance
- J .0050 to .0060 Clearance
- K .0000 to .0005 Preload
- L .0000 to .0010 Preload
- M .0005 to .0010 Preload
- N .0005 to .0015 Preload
- P .0010 to .0020 Preload
- Q .0010 to .0015 Preload
- R .0015 to .0025 Preload
- S .0020 to .0030 Preload
- Z Other clearance or preload not specified above

- Type X or C = Diametral Preload or Clearance
- Duplexed Type A = Axial Preload or Clearance

Note: Above internal bearing fits apply to unmounted bearings only. Mounting fits can greatly affect final internal bearing fit.

Position 10-13—DFAR Compliance

All REALI-SLIM® bearings requiring compliance with Defense Federal Acquisition Regulations (DFAR) clauses 252.225.7014 ALT 1 and 252.225.7016 will contain ‘-USA’ in positions 10-13. If internal fit is not called out in position 9, it will also contain a dash.

Example #1: KG120XP0L-USA

Example #2: KG120XP0--USA

Section 2— Selection Tables for Standard REALI-SLIM® Bearings

- **Open Bearings Inch Series - AISI 52100, Selection Tables - Types A, C, X.....pgs. 15-26**
- **Sealed Bearings - AISI 52100, Selection Tables - Types C, X.....pgs. 27-34**
- **ENDURAKOTE® - Plated Bearings Overview & Selection Tablespgs. 35-48**
- **Open Bearings - AISI 440C, Overview & Selection Tables - Types A, C, X.....pgs. 49-52**
- **Open Bearings Metric Series - AISI 52100, Selection Tables - Types A, C, X.....pgs. 53-59**
- **ULTRA-SLIM™ Bearings Overview & Selection Tables - Types A, C, X.....pgs. 60-61**
- **REALI-SLIM TT™ Turntable Series Overview & Selection Tablespgs. 62-64**

Open REALI-SLIM® Bearing Selections

Type A Angular Contact

A deep groove bearing with reduced shoulder on one side of inner or outer race ball path. Snapover assembly permits use of a one-piece circular pocket ring separator and greater ball complement. These bearings will accept radial load and single direction thrust load and are normally used in conjunction with another bearing of similar construction. Type A bearings require the application

of thrust to establish contact angle. Stock bearings are individual units and when purchased as such must be adjusted at installation to desired running clearance or preload. If preferred, matched sets are available. KAYDON also offers matched spacers for applications requiring extra precision. KAYDON® can provide this service direct from the factory.

KAA SERIES										
KAYDON Bearing Number	Dimensions in Inches					Capacities in Pounds ^①				Weight in Pounds
	Bore	Outside Dia.	Land Dia. L ₁	Land Dia. L ₂	C'Bore Dia. L ₃	Radial		Thrust		
						Static ^②	Dyn.	Static ^②	Dyn.	
KAA10AG0	1.000	1.375	1.140	1.235	1.274	340	194	970	450	.025
KAA15AG0	1.500	1.875	1.640	1.735	1.774	480	238	1,380	560	.038
KAA17AG0	1.750	2.125	1.890	1.985	2.024	530	251	1,520	600	.045

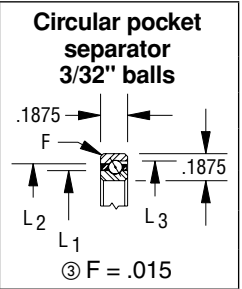

KA SERIES										
KAYDON Bearing Number	Dimensions in Inches					Capacities in Pounds ^①				Weight in Pounds
	Bore	Outside Dia.	Land Dia. L ₁	Land Dia. L ₂	C'Bore Dia. L ₃	Radial		Thrust		
						Static ^②	Dyn.	Static ^②	Dyn.	
KA020AR0	2.000	2.500	2.186	2.314	2.369	790	405	2,280	960	.10
KA025AR0	2.500	3.000	2.686	2.814	2.869	960	459	2,780	1,100	.12
KA030AR0	3.000	3.500	3.186	3.314	3.367	1,140	507	3,290	1,230	.14
KA035AR0	3.500	4.000	3.686	3.814	3.867	1,310	552	3,790	1,350	.17
KA040AR0	4.000	4.500	4.186	4.314	4.367	1,490	595	4,300	1,470	.19
KA042AR0	4.250	4.750	4.436	4.564	4.615	1,580	616	4,550	1,530	.20
KA045AR0	4.500	5.000	4.686	4.814	4.865	1,660	637	4,810	1,580	.21
KA047AR0	4.750	5.250	4.936	5.064	5.115	1,750	657	5,060	1,640	.22
KA050AR0	5.000	5.500	5.186	5.314	5.365	1,840	676	5,310	1,690	.23
KA055AR0	5.500	6.000	5.686	5.814	5.863	2,020	715	5,820	1,800	.25
KA060AR0	6.000	6.500	6.186	6.314	6.363	2,190	752	6,320	1,900	.28
KA065AR0	6.500	7.000	6.686	6.814	6.861	2,370	788	6,830	2,000	.30
KA070AR0	7.000	7.500	7.186	7.314	7.361	2,540	823	7,340	2,100	.32
KA075AR0	7.500	8.000	7.686	7.814	7.861	2,720	857	7,840	2,190	.34
*KA080AR0	8.000	8.500	8.186	8.314	8.359	2,890	890	8,350	2,280	.36
*KA090AR0	9.000	9.500	9.186	9.314	9.357	3,240	954	9,360	2,470	.41
KA100AR0	10.000	10.500	10.186	10.314	10.355	3,590	1,014	10,370	2,640	.45
*KA110AR0	11.000	11.500	11.186	11.314	11.353	3,940	1,072	11,380	2,810	.50
*KA120AR0	12.000	12.500	12.186	12.314	12.349	4,290	1,128	12,390	2,970	.54

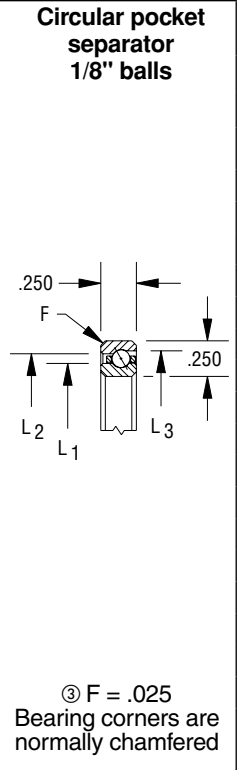

① Capacities listed are not simultaneous. For combined loading see discussion of Bearing Selection and Load Analysis. Dynamic capacities are based upon 1 million revolutions of L10 life. Published capacities do not apply to hybrid series bearings P, X, and Y - contact KAYDON product engineering for values.
 ② Static capacities are non-brinell limits based on rigid support from the shaft and housing.
 ③ "F" is the maximum shaft or housing fillet radius the bearing corners will clear.
 * Contact KAYDON for lead time and minimum purchase requirement.

TYPE A - OPEN REALI-SLIM® BEARINGS, ANGULAR CONTACT

Section 2-Selection Tables

KB SERIES										
KAYDON Bearing Number	Dimensions in Inches					Capacities in Pounds ^①				Weight in Pounds
	Bore	Outside Dia.	Land Dia. L ₁	Land Dia. L ₂	C' Bore Dia. L ₃	Radial		Thrust		
						Static ^②	Dyn.	Static ^②	Dyn.	
KB020AR0	2.000	2.625	2.231	2.393	2.464	1,090	601	3,150	1,380	.15
KB025AR0	2.500	3.125	2.731	2.893	2.964	1,340	675	3,860	1,590	.19
KB030AR0	3.000	3.625	3.231	3.393	3.462	1,550	734	4,470	1,750	.22
KB035AR0	3.500	4.125	3.731	3.893	3.962	1,790	801	5,180	1,930	.27
KB040AR0	4.000	4.625	4.231	4.393	4.460	2,040	865	5,890	2,100	.30
KB042AR0	4.250	4.875	4.481	4.643	4.710	2,150	891	6,200	2,170	.31
*KB045AR0	4.500	5.125	4.731	4.893	4.960	2,250	917	6,500	2,240	.34
*KB047AR0	4.750	5.375	4.981	5.143	5.210	2,390	951	6,910	2,340	.35
*KB050AR0	5.000	5.625	5.231	5.393	5.460	2,500	976	7,210	2,410	.37
KB055AR0	5.500	6.125	5.731	5.893	5.958	2,740	1,033	7,920	2,560	.40
KB060AR0	6.000	6.625	6.231	6.393	6.458	2,990	1,088	8,630	2,710	.44
*KB065AR0	6.500	7.125	6.731	6.893	6.958	3,200	1,132	9,240	2,840	.47
*KB070AR0	7.000	7.625	7.231	7.393	7.456	3,450	1,184	9,960	2,980	.50
*KB075AR0	7.500	8.125	7.731	7.893	7.955	3,700	1,235	10,670	3,120	.54
*KB080AR0	8.000	8.625	8.231	8.393	8.453	3,940	1,284	11,380	3,260	.57
KB090AR0	9.000	9.625	9.231	9.393	9.451	4,400	1,370	12,700	3,510	.64
*KB100AR0	10.000	10.625	10.231	10.393	10.449	4,890	1,461	14,120	3,760	.71
*KB110AR0	11.000	11.625	11.231	11.393	11.447	5,350	1,540	15,440	4,000	.78
*KB120AR0	12.000	12.625	12.231	12.393	12.445	5,840	1,623	16,860	4,240	.85
*KB140AR0	14.000	14.625	14.231	14.393	14.439	6,760	1,767	19,500	4,670	.98
*KB160AR0	16.000	16.625	16.231	16.393	16.433	7,710	1,907	22,250	5,100	1.12
*KB180AR0	18.000	18.625	18.231	18.393	18.425	8,660	2,038	24,990	5,510	1.26
*KB200AR0	20.000	20.625	20.231	20.393	20.416	9,610	2,162	27,730	5,900	1.40

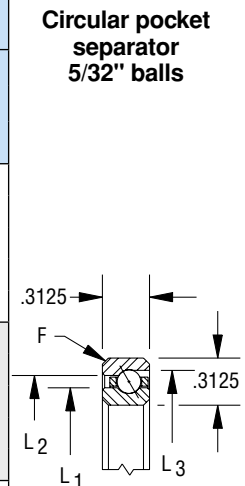

③ F = .040
Bearing corners are normally chamfered

① Capacities listed are not simultaneous. For combined loading see discussion of Bearing Selection and Load Analysis. Dynamic capacities are based upon 1 million revolutions of L10 life. Published capacities do not apply to hybrid series bearings P, X, and Y - contact KAYDON product engineering for values.
 ② Static capacities are non-brinell limits based on rigid support from the shaft and housing.
 ③ "F" is the maximum shaft or housing fillet radius the bearing corners will clear.
 * Contact KAYDON for lead time and minimum purchase requirement.

CONTACT KAYDON AT—
 KAYDON Corporation • Muskegon, Michigan 49443
 Telephone: 231/755-3741 • Fax: 231/759-4102
NEED SERVICE FAST?
 1-800-514-3066
 Website: www.kaydonbearings.com

TYPE A - OPEN REALI-SLIM® BEARINGS, ANGULAR CONTACT

KC SERIES											Circular pocket separator 3/16" balls
KAYDON Bearing Number	Dimensions in Inches					Capacities in Pounds ^①				Weight in Pounds	
	Bore	Outside Dia.	Land Dia. L ₁	Land Dia. L ₂	C'Bore Dia. L ₃	Radial		Thrust			
						Static ^②	Dyn.	Static ^②	Dyn.		
KC040AR0	4.000	4.750	4.277	4.473	4.554	2,550	1,153	7,360	2,770	.44	
*KC042AR0	4.250	5.000	4.527	4.723	4.804	2,710	1,194	7,820	2,880	.46	
KC045AR0	4.500	5.250	4.777	4.973	5.052	2,860	1,234	8,270	2,990	.49	
KC047AR0	4.750	5.500	5.027	5.223	5.302	3,020	1,274	8,720	3,100	.51	
KC050AR0	5.000	5.750	5.277	5.473	5.552	3,180	1,313	9,170	3,200	.54	
KC055AR0	5.500	6.250	5.777	5.973	6.052	3,440	1,374	9,920	3,370	.58	
KC060AR0	6.000	6.750	6.277	6.473	6.550	3,750	1,448	10,820	3,580	.64	
*KC065AR0	6.500	7.250	6.777	6.973	7.050	4,060	1,519	11,720	3,770	.68	
KC070AR0	7.000	7.750	7.277	7.473	7.550	4,320	1,575	12,470	3,930	.74	
*KC075AR0	7.500	8.250	7.777	7.973	8.048	4,630	1,642	13,380	4,120	.78	
KC080AR0	8.000	8.750	8.277	8.473	8.548	4,950	1,708	14,280	4,300	.84	
*KC090AR0	9.000	9.750	9.277	9.473	9.546	5,520	1,822	15,930	4,630	.98	
*KC100AR0	10.000	10.750	10.277	10.473	10.544	6,140	1,942	17,730	4,970	1.04	
*KC110AR0	11.000	11.750	11.277	11.473	11.542	6,720	2,047	19,390	5,280	1.14	
*KC120AR0	12.000	12.750	12.277	12.473	12.540	7,290	2,147	21,040	5,570	1.23	
*KC140AR0	14.000	14.750	14.277	14.473	14.535	8,490	2,347	24,500	6,170	1.43	
*KC160AR0	16.000	16.750	16.277	16.473	16.529	9,680	2,533	27,950	6,730	1.63	
*KC180AR0	18.000	18.750	18.277	18.473	18.523	10,880	2,707	31,410	7,280	1.83	
*KC200AR0	20.000	20.750	20.277	20.473	20.517	12,030	2,863	34,720	7,780	2.03	
*KC250AR0	25.000	25.750	25.277	25.473	25.500	14,900	3,233	43,280	9,010	2.52	
*KC300AR0	30.000	30.750	30.277	30.473	30.484	17,960	3,561	51,850	10,160	3.02	

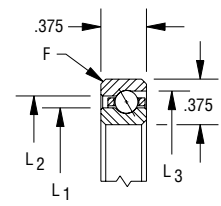

③ F = .040
Bearing corners are normally chamfered

KD SERIES											Circular pocket separator 1/4" balls
KAYDON Bearing Number	Dimensions in Inches					Capacities in Pounds ^①				Weight in Pounds	
	Bore	Outside Dia.	Land Dia. L ₁	Land Dia. L ₂	C'Bore Dia. L ₃	Radial		Thrust			
						Static ^②	Dyn.	Static ^②	Dyn.		
KD040AR0	4.000	5.000	4.370	4.630	4.741	3,550	1,819	10,260	4,260	.80	
KD042AR0	4.250	5.250	4.620	4.880	4.991	3,750	1,876	10,830	4,420	.84	
KD045AR0	4.500	5.500	4.870	5.130	5.241	3,950	1,931	11,400	4,570	.88	
KD047AR0	4.750	5.750	5.120	5.380	5.490	4,150	1,986	11,970	4,720	.93	
KD050AR0	5.000	6.000	5.370	5.630	5.740	4,340	2,040	12,540	4,870	.98	
KD055AR0	5.500	6.500	5.870	6.130	6.238	4,740	2,145	13,680	5,160	1.06	
KD060AR0	6.000	7.000	6.370	6.630	6.738	5,130	2,247	14,820	5,440	1.15	
KD065AR0	6.500	7.500	6.870	7.130	7.236	5,530	2,346	15,960	5,720	1.24	
KD070AR0	7.000	8.000	7.370	7.630	7.736	5,920	2,442	17,100	5,990	1.33	
KD075AR0	7.500	8.500	7.870	8.130	8.236	6,320	2,536	18,240	6,250	1.42	
KD080AR0	8.000	9.000	8.370	8.630	8.734	6,710	2,627	19,380	6,510	1.52	
KD090AR0	9.000	10.000	9.370	9.630	9.732	7,500	2,803	21,660	7,010	1.69	
*KD100AR0	10.000	11.000	10.370	10.630	10.732	8,290	2,972	23,940	7,500	1.87	
*KD110AR0	11.000	12.000	11.370	11.630	11.730	9,080	3,133	26,220	7,960	2.05	
KD120AR0	12.000	13.000	12.370	12.630	12.728	9,870	3,288	28,500	8,420	2.23	
*KD140AR0	14.000	15.000	14.370	14.630	14.724	11,450	3,582	33,060	9,290	2.57	
*KD160AR0	16.000	17.000	16.370	16.630	16.718	13,030	3,856	37,620	10,130	2.93	
*KD180AR0	18.000	19.000	18.370	18.630	18.712	14,610	4,113	42,180	10,930	3.29	
*KD200AR0	20.000	21.000	20.370	20.630	20.705	16,190	4,356	46,740	11,710	3.65	
*KD210AR0	21.000	22.000	21.370	21.630	21.700	16,981	4,472	49,020	12,086	3.83	
*KD250AR0	25.000	26.000	25.370	25.630	25.688	20,140	4,908	58,140	13,540	4.54	
*KD300AR0	30.000	31.000	30.370	30.630	30.672	24,090	5,397	69,540	15,260	5.44	

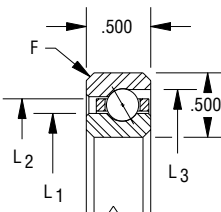

③ F = .060
Bearing corners are normally chamfered

① Capacities listed are not simultaneous. For combined loading see discussion of Bearing Selection and Load Analysis. Dynamic capacities are based upon 1 million revolutions of L10 life. Published capacities do not apply to hybrid series bearings P, X, and Y - contact KAYDON product engineering for values.
 ② Static capacities are non-brinell limits based on rigid support from the shaft and housing.
 ③ "F" is the maximum shaft or housing fillet radius the bearing corners will clear.
 * Contact KAYDON for lead time and minimum purchase requirement.

TYPE A - OPEN REALI-SLIM® BEARINGS, ANGULAR CONTACT

Section 2-Selection Tables

KF SERIES										
KAYDON Bearing Number	Dimensions in Inches					Capacities in Pounds ^①				Weight in Pounds
	Bore	Outside Dia.	Land Dia. L ₁	Land Dia. L ₂	C'Bore Dia. L ₃	Radial		Thrust		
						Static ^②	Dyn.	Static ^②	Dyn.	
*KF040AR0	4.000	5.500	4.555	4.945	5.115	6,350	3,736	18,340	8,420	1.92
*KF042AR0	4.250	5.750	4.805	5.195	5.365	6,600	3,805	19,050	8,630	2.04
*KF045AR0	4.500	6.000	5.060	5.445	5.615	7,090	3,966	20,460	9,050	2.14
KF047AR0	4.750	6.250	5.305	5.695	5.865	7,330	4,034	21,160	9,260	2.26
*KF050AR0	5.000	6.500	5.555	5.945	6.115	7,570	4,101	21,870	9,460	2.37
KF055AR0	5.500	7.000	6.055	6.445	6.613	8,310	4,319	23,980	10,060	2.59
KF060AR0	6.000	7.500	6.555	6.945	7.113	9,040	4,530	26,100	10,650	2.72
KF065AR0	6.500	8.000	7.055	7.445	7.613	9,770	4,734	28,220	11,220	2.94
*KF070AR0	7.000	8.500	7.555	7.945	8.113	10,510	4,932	30,330	11,770	3.16
KF075AR0	7.500	9.000	8.055	8.445	8.610	11,000	5,052	31,740	12,130	3.39
KF080AR0	8.000	9.500	8.555	8.945	9.110	11,730	5,242	33,860	12,670	3.61
KF090AR0	9.000	10.500	9.555	9.945	10.108	13,190	5,608	38,090	13,700	3.95
KF100AR0	10.000	11.500	10.555	10.945	11.106	14,420	5,890	41,620	14,530	4.40
*KF110AR0	11.000	12.500	11.555	11.945	12.106	15,880	6,227	45,850	15,500	4.75
KF120AR0	12.000	13.500	12.555	12.945	13.104	17,100	6,487	49,380	16,290	5.20
*KF140AR0	14.000	15.500	14.555	14.945	15.102	19,790	7,043	57,140	17,950	5.76
*KF160AR0	16.000	17.500	16.555	16.945	17.098	22,480	7,563	64,890	19,540	6.78
*KF180AR0	18.000	19.500	18.555	18.945	19.096	25,410	8,103	73,360	21,210	7.67
*KF200AR0	20.000	21.500	20.555	20.945	21.092	28,100	8,562	81,120	22,680	8.47
*KF250AR0	25.000	26.500	25.555	25.945	26.085	34,700	9,585	100,200	26,100	10.50
*KF300AR0	30.000	31.500	30.555	30.945	31.075	41,540	10,533	119,900	29,430	12.50
*KF350AR0	35.000	36.500	35.555	35.945	36.064	48,380	11,382	139,700	32,580	14.60
*KF400AR0	40.000	41.500	40.555	40.945	41.054	55,220	12,147	159,400	35,580	16.60

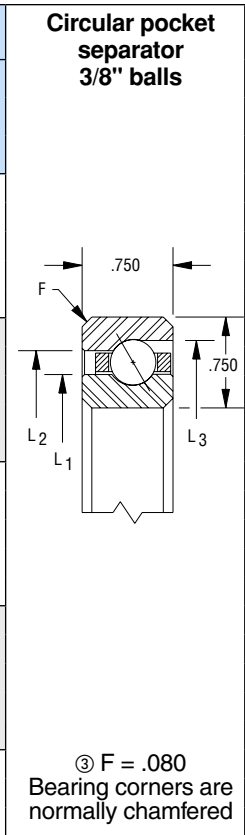

KG SERIES										
KAYDON Bearing Number	Dimensions in Inches					Capacities in Pounds ^①				Weight in Pounds
	Bore	Outside Dia.	Land Dia. L ₁	Land Dia. L ₂	C'Bore Dia. L ₃	Radial		Thrust		
						Static ^②	Dyn.	Static ^②	Dyn.	
*KG040AR0	4.000	6.000	4.742	5.258	5.491	9,480	6,281	27,360	13,630	3.61
*KG042AR0	4.250	6.250	4.992	5.508	5.741	9,950	6,438	28,730	14,090	3.83
*KG045AR0	4.500	6.500	5.242	5.758	5.989	10,430	6,562	30,100	14,530	3.95
*KG047AR0	4.750	6.750	5.492	6.008	6.239	10,900	6,745	31,460	14,970	4.17
*KG050AR0	5.000	7.000	5.742	6.258	6.489	11,370	6,897	32,830	15,400	4.42
*KG055AR0	5.500	7.500	6.242	6.758	6.989	12,320	7,192	35,570	16,240	4.73
KG060AR0	6.000	8.000	6.742	7.258	7.489	13,270	7,480	38,300	17,060	5.07
*KG065AR0	6.500	8.500	7.242	7.758	7.987	14,220	7,761	41,040	17,870	5.41
*KG070AR0	7.000	9.000	7.742	8.258	8.487	15,160	8,035	43,780	18,650	5.87
KG075AR0	7.500	9.500	8.242	8.758	8.987	16,110	8,303	46,510	19,420	6.20
KG080AR0	8.000	10.000	8.742	9.258	9.485	17,060	8,566	49,250	20,180	6.54
KG090AR0	9.000	11.000	9.742	10.258	10.485	18,960	9,073	54,720	21,640	7.22
KG100AR0	10.000	12.000	10.742	11.258	11.483	20,850	9,561	60,190	23,060	8.00
*KG110AR0	11.000	13.000	11.742	12.258	12.481	22,750	10,027	65,660	24,440	8.68
KG120AR0	12.000	14.000	12.742	13.258	13.481	24,640	10,481	71,140	25,780	9.47
KG140AR0	14.000	16.000	14.742	15.258	15.478	28,430	11,338	82,080	28,360	10.90
KG160AR0	16.000	18.000	16.742	17.258	17.474	32,220	12,142	93,020	30,830	12.40
KG180AR0	18.000	20.000	18.742	19.258	19.472	36,020	12,898	104,000	33,200	13.80
KG200AR0	20.000	22.000	20.742	21.258	21.468	39,810	13,612	114,900	35,490	15.20
*KG220AR0	22.000	24.000	22.742	23.258	23.468	43,598	14,290	125,856	37,712	16.63
*KG250AR0	25.000	27.000	25.742	26.258	26.461	49,280	15,239	142,300	40,920	18.80
*KG300AR0	30.000	32.000	30.742	31.258	31.451	58,760	16,687	169,600	46,020	22.50
KG350AR0	35.000	37.000	35.742	36.258	36.440	68,240	17,982	197,000	50,840	26.20
*KG400AR0	40.000	42.000	40.742	41.258	41.430	77,720	19,153	224,400	55,440	29.80

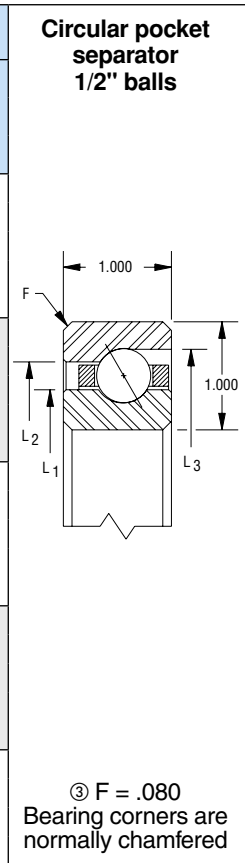

① Capacities listed are not simultaneous. For combined loading see discussion of Bearing Selection and Load Analysis. Dynamic capacities are based upon 1 million revolutions of L10 life. Published capacities do not apply to hybrid series bearings P, X, and Y - contact KAYDON product engineering for values.
 ② Static capacities are non-brinell limits based on rigid support from the shaft and housing.
 ③ "F" is the maximum shaft or housing fillet radius the bearing corners will clear.
 * Contact KAYDON for lead time and minimum purchase requirement.

Open REALI-SLIM® Bearing Selections

Type C

Radial Contact

A Conrad assembled bearing designed primarily for application of radial load—deep ball grooves also permit application of thrust load in either direction – often used in conjunction with another bearing.

KAA SERIES							
KAYDON Bearing Number	Dimensions in Inches				Radial Capacities in Pounds ^①		Weight in Pounds
	Bore	Outside Dia.	Land Dia. L ₁	Land Dia. L ₂	Static ^②	Dyn.	
KAA10CL0	1.000	1.375	1.140	1.235	290	188	.026
KAA15CL0	1.500	1.875	1.640	1.735	400	225	.039
KAA17CL0	1.750	2.125	1.890	1.985	460	242	.045

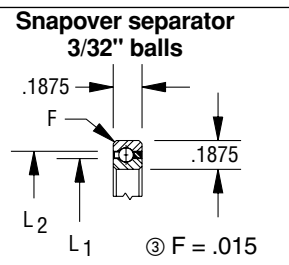

KA SERIES							
KAYDON Bearing Number	Dimensions in Inches				Radial Capacities in Pounds ^①		Weight in Pounds
	Bore	Outside Dia.	Land Dia. L ₁	Land Dia. L ₂	Static ^②	Dyn.	
KA020CP0	2.000	2.500	2.186	2.314	680	393	.10
KA025CP0	2.500	3.000	2.686	2.814	830	442	.13
KA030CP0	3.000	3.500	3.186	3.314	990	487	.15
KA035CP0	3.500	4.000	3.686	3.814	1,140	530	.18
KA040CP0	4.000	4.500	4.186	4.314	1,290	571	.19
KA042CP0	4.250	4.750	4.436	4.564	1,370	591	.20
KA045CP0	4.500	5.000	4.686	4.814	1,440	610	.22
KA047CP0	4.750	5.250	4.936	5.064	1,520	629	.23
KA050CP0	5.000	5.500	5.186	5.314	1,590	648	.24
KA055CP0	5.500	6.000	5.686	5.814	1,750	685	.25
KA060CP0	6.000	6.500	6.186	6.314	1,900	720	.28
KA065CP0	6.500	7.000	6.686	6.814	2,050	754	.30
KA070CP0	7.000	7.500	7.186	7.314	2,200	787	.31
KA075CP0	7.500	8.000	7.686	7.814	2,350	820	.34
KA080CP0	8.000	8.500	8.186	8.314	2,500	851	.38
KA090CP0	9.000	9.500	9.186	9.314	2,810	912	.44
KA100CP0	10.000	10.500	10.186	10.314	3,110	969	.50
KA110CP0	11.000	11.500	11.186	11.314	3,410	1,025	.52
KA120CP0	12.000	12.500	12.186	12.314	3,720	1,078	.56

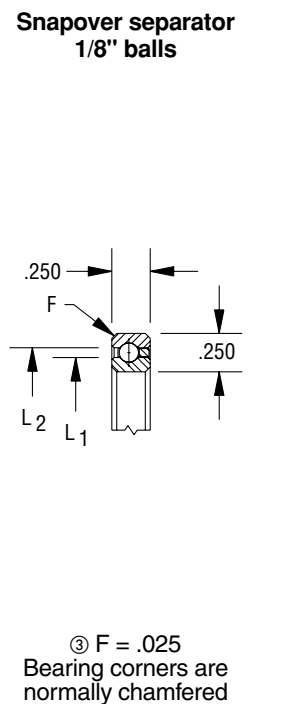

① Capacities listed are not simultaneous. For combined loading see discussion of Bearing Selection and Load Analysis. Dynamic capacities are based upon 1 million revolutions of L10 life. Published capacities do not apply to hybrid series bearings P, X, and Y - contact KAYDON product engineering for values.

② Static capacities are non-brinell limits based on rigid support from the shaft and housing.

③ "F" is the maximum shaft or housing fillet radius the bearing corners will clear.

* Contact KAYDON for lead time and minimum purchase requirement.

TYPE C - OPEN REALI-SLIM® BEARINGS, RADIAL CONTACT

KB SERIES							
KAYDON Bearing Number	Dimensions in Inches				Radial Capacities in Pounds ^①		Weight in Pounds
	Bore	Outside Dia.	Land Dia. L ₁	Land Dia. L ₂	Static ^②	Dyn.	
KB020CP0	2.000	2.625	2.231	2.393	930	577	.16
KB025CP0	2.500	3.125	2.731	2.893	1,140	644	.20
KB030CP0	3.000	3.625	3.231	3.393	1,340	707	.24
KB035CP0	3.500	4.125	3.731	3.893	1,540	767	.27
KB040CP0	4.000	4.625	4.231	4.393	1,750	825	.30
KB042CP0	4.250	4.875	4.481	4.643	1,830	846	.31
KB045CP0	4.500	5.125	4.731	4.893	1,950	880	.33
*KB047CP0	4.750	5.375	4.981	5.143	2,030	901	.34
KB050CP0	5.000	5.625	5.231	5.393	2,150	933	.38
*KB055CP0	5.500	6.125	5.731	5.893	2,360	984	.41
KB060CP0	6.000	6.625	6.231	6.393	2,560	1,034	.44
KB065CP0	6.500	7.125	6.731	6.893	2,760	1,082	.47
*KB070CP0	7.000	7.625	7.231	7.393	2,970	1,129	.50
*KB075CP0	7.500	8.125	7.731	7.893	3,170	1,175	.53
KB080CP0	8.000	8.625	8.231	8.393	3,370	1,219	.57
*KB090CP0	9.000	9.625	9.231	9.393	3,780	1,304	.66
*KB100CP0	10.000	10.625	10.231	10.393	4,190	1,386	.73
*KB110CP0	11.000	11.625	11.231	11.393	4,590	1,464	.75
*KB120CP0	12.000	12.625	12.231	12.393	5,000	1,539	.83
*KB140CP0	14.000	14.625	14.231	14.393	5,810	1,680	1.05
*KB160CP0	16.000	16.625	16.231	16.393	6,620	1,812	1.20
*KB180CP0	18.000	18.625	18.231	18.393	7,440	1,936	1.35
*KB200CP0	20.000	20.625	20.231	20.393	8,250	2,053	1.50

Snapover separator
5/32" balls

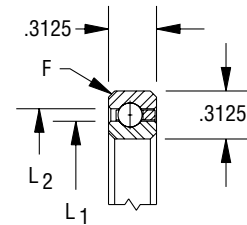

③ F = .040
Bearing corners are normally chamfered

① Capacities listed are not simultaneous. For combined loading see discussion of Bearing Selection and Load Analysis. Dynamic capacities are based upon 1 million revolutions of L10 life. Published capacities do not apply to hybrid series bearings P, X, and Y - contact KAYDON product engineering for values.
 ② Static capacities are non-brinell limits based on rigid support from the shaft and housing.
 ③ "F" is the maximum shaft or housing fillet radius the bearing corners will clear.
 * Contact KAYDON for lead time and minimum purchase requirement.

CONTACT KAYDON AT—
 KAYDON Corporation • Muskegon, Michigan 49443
 Telephone: 231/755-3741 • Fax: 231/759-4102
NEED SERVICE FAST?
 1-800-514-3066
 Website: www.kaydonbearings.com

TYPE C - OPEN REALI-SLIM® BEARINGS, RADIAL CONTACT

KC SERIES								Snapover separator 3/16" balls
KAYDON Bearing Number	Dimensions in Inches				Radial Capacities in Pounds ^①		Weight in Pounds	
	Bore	Outside Dia.	Land Dia. L ₁	Land Dia. L ₂	Static ^②	Dyn.		
KC040CP0	4.000	4.750	4.277	4.473	2,100	1,073	.45	
KC042CP0	4.250	5.000	4.527	4.723	2,220	1,108	.47	
KC045CP0	4.500	5.250	4.777	4.973	2,340	1,143	.48	
KC047CP0	4.750	5.500	5.027	5.223	2,460	1,176	.50	
KC050CP0	5.000	5.750	5.277	5.473	2,590	1,209	.58	
KC055CP0	5.500	6.250	5.777	5.973	2,830	1,274	.59	
KC060CP0	6.000	6.750	6.277	6.473	3,070	1,337	.63	
KC065CP0	6.500	7.250	6.777	6.973	3,310	1,397	.68	
KC070CP0	7.000	7.750	7.277	7.473	3,550	1,457	.73	
KC075CP0	7.500	8.250	7.777	7.973	3,790	1,514	.78	
KC080CP0	8.000	8.750	8.277	8.473	4,030	1,570	.84	
KC090CP0	9.000	9.750	9.277	9.473	4,510	1,678	.94	
KC100CP0	10.000	10.750	10.277	10.473	4,990	1,781	1.06	
*KC110CP0	11.000	11.750	11.277	11.473	5,470	1,879	1.16	
KC120CP0	12.000	12.750	12.277	12.473	5,950	1,974	1.25	
KC140CP0	14.000	14.750	14.277	14.473	6,910	2,154	1.52	
KC160CP0	16.000	16.750	16.277	16.473	7,880	2,321	1.73	
*KC180CP0	18.000	18.750	18.277	18.473	8,840	2,478	1.94	
*KC200CP0	20.000	20.750	20.277	20.473	9,800	2,626	2.16	
*KC250CP0	25.000	25.750	25.277	25.473	12,200	2,962	2.69	
*KC300CP0	30.000	30.750	30.277	30.473	14,610	3,260	3.21	

③ F = .040
Bearing corners are normally chamfered

KD SERIES								Snapover separator 1/4" balls
KAYDON Bearing Number	Dimensions in Inches				Radial Capacities in Pounds ^①		Weight in Pounds	
	Bore	Outside Dia.	Land Dia. L ₁	Land Dia. L ₂	Static ^②	Dyn.		
KD040CP0	4.000	5.000	4.370	4.630	3,080	1,755	.78	
KD042CP0	4.250	5.250	4.620	4.880	3,190	1,787	.83	
KD045CP0	4.500	5.500	4.870	5.130	3,420	1,861	.88	
KD047CP0	4.750	5.750	5.120	5.380	3,530	1,892	.94	
KD050CP0	5.000	6.000	5.370	5.630	3,760	1,964	1.00	
KD055CP0	5.500	6.500	5.870	6.130	4,100	2,063	1.06	
KD060CP0	6.000	7.000	6.370	6.630	4,450	2,160	1.16	
KD065CP0	6.500	7.500	6.870	7.130	4,790	2,254	1.22	
KD070CP0	7.000	8.000	7.370	7.630	5,130	2,345	1.31	
KD075CP0	7.500	8.500	7.870	8.130	5,470	2,434	1.41	
KD080CP0	8.000	9.000	8.370	8.630	5,810	2,520	1.53	
KD090CP0	9.000	10.000	9.370	9.630	6,500	2,688	1.72	
KD100CP0	10.000	11.000	10.370	10.630	7,180	2,847	1.88	
KD110CP0	11.000	12.000	11.370	11.630	7,870	3,000	2.06	
KD120CP0	12.000	13.000	12.370	12.630	8,550	3,148	2.25	
*KD140CP0	14.000	15.000	14.370	14.630	9,920	3,427	2.73	
*KD160CP0	16.000	17.000	16.370	16.630	11,290	3,688	3.10	
*KD180CP0	18.000	19.000	18.370	18.630	12,650	3,933	3.48	
*KD200CP0	20.000	21.000	20.370	20.630	14,020	4,164	3.85	
*KD210CP0	21.000	22.000	21.370	21.630	14,706	4,274	4.04	
*KD250CP0	25.000	26.000	25.370	25.630	17,440	4,689	4.79	
*KD300CP0	30.000	31.000	30.370	30.360	20,860	5,153	5.73	

③ F = .060
Bearing corners are normally chamfered

① Capacities listed are not simultaneous. For combined loading see discussion of Bearing Selection and Load Analysis. Dynamic capacities are based upon 1 million revolutions of L10 life. Published capacities do not apply to hybrid series bearings P, X, and Y - contact KAYDON product engineering for values.
 ② Static capacities are non-brinell limits based on rigid support from the shaft and housing.
 ③ "F" is the maximum shaft or housing fillet radius the bearing corners will clear.
 * Contact KAYDON for lead time and minimum purchase requirement.

TYPE C - OPEN REALI-SLIM® BEARINGS, RADIAL CONTACT

Section 2-Selection Tables

KF SERIES							
KAYDON Bearing Number	Dimensions in Inches				Radial Capacities in Pounds ^①		Weight in Pounds
	Bore	Outside Dia.	Land Dia. L ₁	Land Dia. L ₂	Static ^②	Dyn.	
KF040CP0	4.000	5.500	4.555	4.945	5,360	3,559	1.9
KF042CP0	4.250	5.750	4.805	5.195	5,640	3,655	2.0
*KF045CP0	4.500	6.000	5.055	5.445	5,930	3,750	2.1
KF047CP0	4.750	6.250	5.305	5.695	6,210	3,843	2.2
KF050CP0	5.000	6.500	5.555	5.945	6,490	3,936	2.3
KF055CP0	5.500	7.000	6.055	6.445	7,050	4,116	2.5
KF060CP0	6.000	7.500	6.555	6.945	7,620	4,291	2.7
KF065CP0	6.500	8.000	7.055	7.445	8,180	4,461	2.9
*KF070CP0	7.000	8.500	7.555	7.945	8,750	4,628	3.2
KF075CP0	7.500	9.000	8.055	8.445	9,310	4,791	3.4
KF080CP0	8.000	9.500	8.555	8.945	9,880	4,949	3.5
KF090CP0	9.000	10.500	9.555	9.945	11,000	5,256	3.9
KF100CP0	10.000	11.500	10.555	10.945	12,130	5,550	4.3
KF110CP0	11.000	12.500	11.555	11.945	13,260	5,833	4.8
KF120CP0	12.000	13.500	12.555	12.945	14,390	6,105	5.2
*KF140CP0	14.000	15.500	14.555	14.945	16,650	6,620	6.0
*KF160CP0	16.000	17.500	16.555	16.945	18,900	7,104	7.1
*KF180CP0	18.000	19.500	18.555	18.945	21,160	7,557	7.9
*KF200CP0	20.000	21.500	20.555	20.945	23,420	7,986	8.9
*KF250CP0	25.000	26.500	25.555	25.945	29,060	8,963	10.9
*KF300CP0	30.000	31.500	30.555	30.945	34,700	9,828	13.0
*KF350CP0	35.000	36.500	35.555	35.945	40,350	10,603	15.1
*KF400CP0	40.000	41.500	40.555	40.945	45,990	11,302	17.2

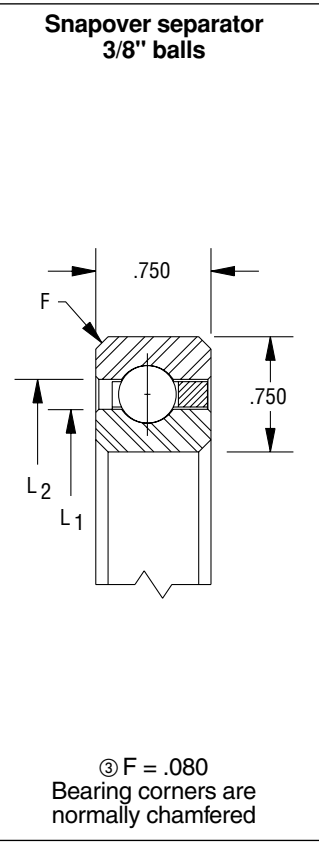

KG SERIES							
KAYDON Bearing Number	Dimensions in Inches				Radial Capacities in Pounds ^①		Weight in Pounds
	Bore	Outside Dia.	Land Dia. L ₁	Land Dia. L ₂	Static ^②	Dyn.	
*KG040CP0	4.000	6.000	4.742	5.258	8,210	6,115	3.6
*KG042CP0	4.250	6.250	4.992	5.508	8,210	6,061	3.8
*KG045CP0	4.500	6.500	5.242	5.758	8,760	6,277	4.0
*KG047CP0	4.750	6.750	5.492	6.008	9,300	6,487	4.1
KG050CP0	5.000	7.000	5.742	6.258	9,850	6,691	4.3
*KG055CP0	5.500	7.500	6.242	6.758	10,400	6,850	4.7
*KG060CP0	6.000	8.000	6.742	7.258	11,490	7,241	5.1
KG065CP0	6.500	8.500	7.242	7.758	12,040	7,393	5.4
*KG070CP0	7.000	9.000	7.742	8.258	13,130	7,764	5.8
KG075CP0	7.500	9.500	8.242	8.758	13,680	7,911	6.1
KG080CP0	8.000	10.000	8.742	9.258	14,770	8,265	6.5
KG090CP0	9.000	11.000	9.742	10.258	16,420	8,743	7.2
KG100CP0	10.000	12.000	10.742	11.258	18,060	9,204	7.9
KG110CP0	11.000	13.000	11.742	12.258	19,700	9,648	8.6
KG120CP0	12.000	14.000	12.742	13.258	21,340	10,074	9.3
KG140CP0	14.000	16.000	14.742	15.258	24,620	10,886	10.8
KG160CP0	16.000	18.000	16.742	17.258	27,910	11,648	12.3
KG180CP0	18.000	20.000	18.742	19.258	31,190	12,367	13.7
KG200CP0	20.000	22.000	20.742	21.258	34,470	13,044	15.8
*KG220CP0	22.000	24.000	22.742	23.258	37,757	13,685	16.8
*KG250CP0	25.000	27.000	25.742	26.258	42,680	14,591	19.5
*KG300CP0	30.000	32.000	30.742	31.258	50,890	15,963	23.3
*KG350CP0	35.000	37.000	35.742	36.258	59,100	17,195	27.1
*KG400CP0	40.000	42.000	40.742	41.258	67,310	18,307	30.8

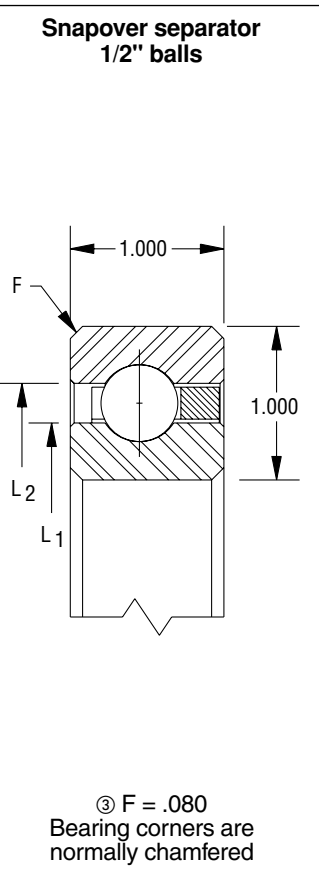

① Capacities listed are not simultaneous. For combined loading see discussion of Bearing Selection and Load Analysis. Dynamic capacities are based upon 1 million revolutions of L10 life. Published capacities do not apply to hybrid series bearings P, X, and Y - contact KAYDON product engineering for values.
 ② Static capacities are non-brinell limits based on rigid support from the shaft and housing.
 ③ "F" is the maximum shaft or housing fillet radius the bearing corners will clear.
 * Contact KAYDON for lead time and minimum purchase requirement.

Open REALI-SLIM® Bearing Selections

Type X

Four-Point Contact

A Conrad assembled bearing designed for applications involving multiple loads. Unique internal geometry permits application of radial load, thrust load in either direction, and moment load, individually or in any combination. A single four-point contact bearing may replace two bearings in many applications.

KAA SERIES											
KAYDON Bearing Number	Dimensions in Inches				Capacities ^①						Weight in Pounds
	Bore	Outside Dia.	Land Dia. L ₁	Land Dia. L ₂	Radial (lbs)		Thrust (lbs)		Moment (in-lbs)		
					Static ^②	Dyn.	Static ^②	Dyn.	Static ^②	Dyn.	
KAA10XL0	1.000	1.375	1.140	1.235	290	247	730	370	170	110	.026
KAA15XL0	1.500	1.875	1.640	1.735	400	296	1,000	460	340	187	.039
KAA17XL0	1.750	2.125	1.890	1.985	460	319	1,140	500	440	232	.045

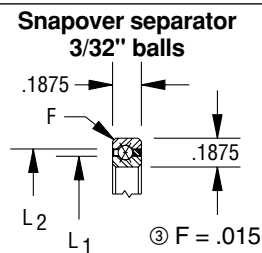

KA SERIES											
KAYDON Bearing Number	Dimensions in Inches				Capacities ^①						Weight in Pounds
	Bore	Outside Dia.	Land Dia. L ₁	Land Dia. L ₂	Radial (lbs)		Thrust (lbs)		Moment (in-lbs)		
					Static ^②	Dyn.	Static ^②	Dyn.	Static ^②	Dyn.	
KA020XP0	2.000	2.500	2.186	2.314	680	514	1,710	790	770	434	.10
KA025XP0	2.500	3.000	2.686	2.814	830	583	2,090	910	1,150	601	.13
KA030XP0	3.000	3.500	3.186	3.314	990	643	2,470	1,010	1,600	785	.15
KA035XP0	3.500	4.000	3.686	3.814	1,140	701	2,850	1,110	2,130	986	.18
KA040XP0	4.000	4.500	4.186	4.314	1,290	756	3,220	1,210	2,740	1,205	.19
KA042XP0	4.250	4.750	4.436	4.564	1,370	783	3,410	1,260	3,070	1,321	.20
KA045XP0	4.500	5.000	4.686	4.814	1,440	809	3,600	1,310	3,420	1,441	.22
KA047XP0	4.750	5.250	4.936	5.064	1,520	834	3,790	1,350	3,790	1,565	.23
KA050XP0	5.000	5.500	5.186	5.314	1,590	859	3,980	1,400	4,180	1,693	.24
KA055XP0	5.500	6.000	5.686	5.814	1,750	908	4,360	1,480	5,020	1,959	.25
KA060XP0	6.000	6.500	6.186	6.314	1,900	955	4,740	1,570	5,930	2,240	.28
KA065XP0	6.500	7.000	6.686	6.814	2,050	1,001	5,120	1,650	6,910	2,535	.30
KA070XP0	7.000	7.500	7.186	7.314	2,200	1,046	5,500	1,730	7,980	2,844	.31
KA075XP0	7.500	8.000	7.686	7.814	2,350	1,089	5,880	1,810	9,120	3,165	.34
KA080XP0	8.000	8.500	8.186	8.314	2,500	1,131	6,260	1,890	10,330	3,499	.38
KA090XP0	9.000	9.500	9.186	9.314	2,810	1,212	7,020	2,040	12,990	4,204	.44
KA100XP0	10.000	10.500	10.186	10.314	3,110	1,289	7,780	2,180	15,940	4,956	.50
*KA110XP0	11.000	11.500	11.186	11.314	3,410	1,362	8,540	2,320	19,210	5,750	.52
KA120XP0	12.000	12.500	12.186	12.314	3,720	1,433	9,300	2,450	22,770	6,587	.56

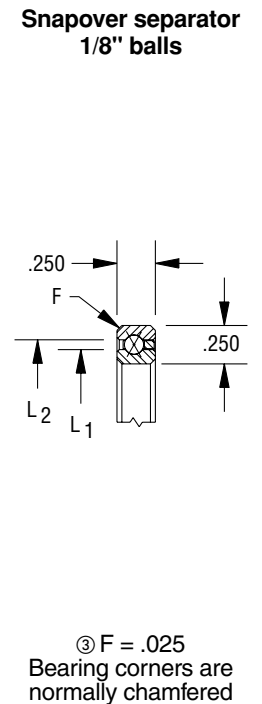

① Capacities listed are not simultaneous. For combined loading see discussion of Bearing Selection and Load Analysis. Dynamic capacities are based upon 1 million revolutions of L10 life. Published capacities do not apply to hybrid series bearings P, X, and Y - contact KAYDON product engineering for values.

② Static capacities are non-brinell limits based on rigid support from the shaft and housing.

③ "F" is the maximum shaft or housing fillet radius the bearing corners will clear.

* Contact KAYDON for lead time and minimum purchase requirement.

TYPE X - OPEN REALI-SLIM® BEARINGS, FOUR-POINT CONTACT

KB SERIES											
KAYDON Bearing Number	Dimensions in Inches				Capacities ^①						Weight in Pounds
	Bore	Outside Dia.	Land Dia. L ₁	Land Dia. L ₂	Radial (lbs)		Thrust (lbs)		Moment (in-lbs)		
					Static ^②	Dyn.	Static ^②	Dyn.	Static ^②	Dyn.	
KB020XP0	2.000	2.625	2.231	2.393	930	758	2,340	1,130	1,080	658	.16
KB025XP0	2.500	3.125	2.731	2.893	1,140	848	2,840	1,290	1,600	895	.19
KB030XP0	3.000	3.625	3.231	3.393	1,340	933	3,350	1,440	2,220	1,159	.24
KB035XP0	3.500	4.125	3.731	3.893	1,540	1,014	3,860	1,590	2,940	1,450	.27
KB040XP0	4.000	4.625	4.231	4.393	1,750	1,091	4,370	1,720	3,770	1,764	.30
KB042XP0	4.250	4.875	4.481	4.643	1,830	1,120	4,570	1,780	4,170	1,917	.31
KB045XP0	4.500	5.125	4.731	4.893	1,950	1,165	4,880	1,850	4,690	2,103	.33
*KB047XP0	4.750	5.375	4.981	5.143	2,030	1,193	5,080	1,900	5,140	2,265	.34
KB050XP0	5.000	5.625	5.231	5.393	2,150	1,236	5,380	1,980	5,720	2,463	.38
KB055XP0	5.500	6.125	5.731	5.893	2,360	1,304	5,890	2,100	6,850	2,844	.41
KB060XP0	6.000	6.625	6.231	6.393	2,560	1,371	6,400	2,220	8,080	3,247	.44
KB065XP0	6.500	7.125	6.731	6.893	2,760	1,435	6,910	2,340	9,410	3,668	.47
*KB070XP0	7.000	7.625	7.231	7.393	2,970	1,498	7,420	2,450	10,850	4,109	.50
*KB075XP0	7.500	8.125	7.731	7.893	3,170	1,559	7,920	2,560	12,380	4,568	.53
KB080XP0	8.000	8.625	8.231	8.393	3,370	1,618	8,430	2,670	14,020	5,045	.57
KB090XP0	9.000	9.625	9.231	9.393	3,780	1,732	9,450	2,880	17,600	6,050	.66
*KB100XP0	10.000	10.625	10.231	10.393	4,190	1,841	10,460	3,080	21,580	7,121	.73
*KB110XP0	11.000	11.625	11.231	11.393	4,590	1,945	11,480	3,280	25,970	8,254	.75
*KB120XP0	12.000	12.625	12.231	12.393	5,000	2,045	12,500	3,470	30,770	9,446	.83
*KB140XP0	14.000	14.625	14.231	14.393	5,810	2,234	14,530	3,840	41,580	11,994	1.05
KB160XP0	16.000	16.625	16.231	16.393	6,620	2,410	16,560	4,190	54,020	14,750	1.20
*KB180XP0	18.000	18.625	18.231	18.393	7,440	2,576	18,590	4,520	68,090	17,694	1.35
*KB200XP0	20.000	20.625	20.231	20.393	8,250	2,731	20,620	4,850	83,780	20,813	1.50

Snapover separator
5/32" balls

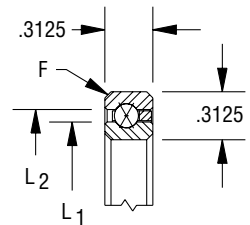

③ F = .040
Bearing corners are normally chamfered

① Capacities listed are not simultaneous. For combined loading see discussion of Bearing Selection and Load Analysis. Dynamic capacities are based upon 1 million revolutions of L10 life. Published capacities do not apply to hybrid series bearings P, X, and Y - contact KAYDON product engineering for values.
 ② Static capacities are non-brinell limits based on rigid support from the shaft and housing.
 ③ "F" is the maximum shaft or housing fillet radius the bearing corners will clear.
 * Contact KAYDON for lead time and minimum purchase requirement.

CONTACT KAYDON AT—
 KAYDON Corporation • Muskegon, Michigan 49443
 Telephone: 231/755-3741 • Fax: 231/759-4102

NEED SERVICE FAST?
1-800-514-3066
 Website: www.kaydonbearings.com

TYPE X - OPEN REALI-SLIM® BEARINGS, FOUR-POINT CONTACT

KC SERIES											
KAYDON Bearing Number	Dimensions in Inches				Capacities ^①						Weight in Pounds
	Bore	Outside Dia.	Land Dia. L ₁	Land Dia. L ₂	Radial (lbs)		Thrust (lbs)		Moment (in-lbs)		
					Static ^②	Dyn.	Static ^②	Dyn.	Static ^②	Dyn.	
KC040XP0	4.000	4.750	4.277	4.473	2,100	1,417	5,260	2,210	4,600	2,326	.45
*KC042XP0	4.250	5.000	4.527	4.723	2,220	1,464	5,560	2,290	5,140	2,541	.47
KC045XP0	4.500	5.250	4.777	4.973	2,340	1,510	5,860	2,380	5,710	2,762	.48
KC047XP0	4.750	5.500	5.027	5.223	2,460	1,556	6,160	2,460	6,320	2,991	.50
KC050XP0	5.000	5.750	5.277	5.473	2,590	1,600	6,460	2,540	6,950	3,226	.58
KC055XP0	5.500	6.250	5.777	5.973	2,830	1,687	7,060	2,690	8,300	3,717	.59
KC060XP0	6.000	6.750	6.277	6.473	3,070	1,770	7,660	2,840	9,770	4,234	.63
KC065XP0	6.500	7.250	6.777	6.973	3,310	1,851	8,270	2,990	11,370	4,775	.68
KC070XP0	7.000	7.750	7.277	7.473	3,550	1,931	8,870	3,130	13,080	5,341	.73
*KC075XP0	7.500	8.250	7.777	7.973	3,790	2,007	9,470	3,270	14,910	5,930	.78
KC080XP0	8.000	8.750	8.277	8.473	4,030	2,082	10,070	3,410	16,870	6,542	.84
KC090XP0	9.000	9.750	9.277	9.473	4,510	2,226	11,270	3,670	21,130	7,830	.94
KC100XP0	10.000	10.750	10.277	10.473	4,990	2,364	12,470	3,930	25,880	9,201	1.06
KC110XP0	11.000	11.750	11.277	11.473	5,470	2,496	13,680	4,180	31,110	10,651	1.16
KC120XP0	12.000	12.750	12.277	12.473	5,950	2,622	14,880	4,420	36,830	12,174	1.25
KC140XP0	14.000	14.750	14.277	14.473	6,910	2,862	17,280	4,890	49,690	15,434	1.52
KC160XP0	16.000	16.750	16.277	16.473	7,880	3,086	19,690	5,330	64,480	18,955	1.73
*KC180XP0	18.000	18.750	18.277	18.473	8,840	3,295	22,090	5,760	81,190	22,712	1.94
*KC200XP0	20.000	20.750	20.277	20.473	9,800	3,492	24,500	6,170	99,830	26,695	2.16
*KC250XP0	25.000	25.750	25.277	25.473	12,200	3,941	30,510	7,140	154,800	37,518	2.69
*KC300XP0	30.000	30.750	30.277	30.473	14,610	4,338	36,520	8,050	221,900	49,436	3.21

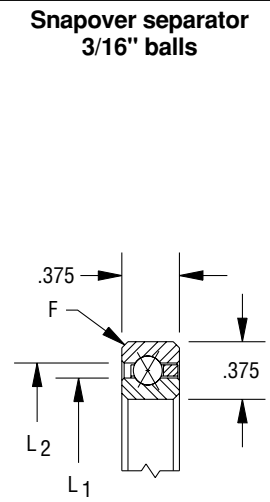

③ F = .040
Bearing corners are normally chamfered

KD SERIES											
KAYDON Bearing Number	Dimensions in Inches				Capacities ^①						Weight in Pounds
	Bore	Outside Dia.	Land Dia. L ₁	Land Dia. L ₂	Radial (lbs)		Thrust (lbs)		Moment (in-lbs)		
					Static ^②	Dyn.	Static ^②	Dyn.	Static ^②	Dyn.	
KD040XP0	4.000	5.000	4.370	4.630	3,080	2,311	7,700	3,520	6,930	3,901	.78
KD042XP0	4.250	5.250	4.620	4.880	3,190	2,355	7,980	3,600	7,580	4,196	.83
KD045XP0	4.500	5.500	4.870	5.130	3,420	2,454	8,550	3,770	8,550	4,602	.88
KD047XP0	4.750	5.750	5.120	5.380	3,530	2,496	8,840	3,860	9,280	4,916	.94
KD050XP0	5.000	6.000	5.370	5.630	3,760	2,592	9,410	4,020	10,350	5,348	1.00
KD055XP0	5.500	6.500	5.870	6.130	4,100	2,725	10,260	4,260	12,310	6,134	1.06
KD060XP0	6.000	7.000	6.370	6.630	4,450	2,855	11,120	4,490	14,450	6,961	1.16
KD065XP0	6.500	7.500	6.870	7.130	4,790	2,980	11,970	4,720	16,760	7,826	1.22
KD070XP0	7.000	8.000	7.370	7.630	5,130	3,103	12,830	4,940	19,240	8,730	1.31
KD075XP0	7.500	8.500	7.870	8.130	5,470	3,222	13,680	5,160	21,890	9,669	1.41
KD080XP0	8.000	9.000	8.370	8.630	5,810	3,338	14,540	5,370	24,710	10,643	1.53
KD090XP0	9.000	10.000	9.370	9.630	6,500	3,561	16,250	5,790	30,870	12,693	1.72
KD100XP0	10.000	11.000	10.370	10.630	7,180	3,776	17,960	6,190	37,710	14,872	1.88
KD110XP0	11.000	12.000	11.370	11.630	7,870	3,981	19,670	6,570	45,230	17,173	2.06
KD120XP0	12.000	13.000	12.370	12.630	8,550	4,178	21,380	6,950	53,440	19,590	2.25
KD140XP0	14.000	15.000	14.370	14.630	9,920	4,551	24,800	7,670	71,910	24,755	2.73
*KD160XP0	16.000	17.000	16.370	16.630	11,290	4,899	28,220	8,360	93,110	30,325	3.10
KD180XP0	18.000	19.000	18.370	18.630	12,650	5,226	31,640	9,030	117,000	36,268	3.48
KD200XP0	20.000	21.000	20.370	20.630	14,020	5,534	35,060	9,670	143,700	42,561	3.85
*KD210XP0	21.000	22.000	21.370	21.630	14,710	5,682	36,770	9,980	158,100	45,826	4.04
*KD250XP0	25.000	26.000	25.370	25.630	17,440	6,235	43,610	11,180	222,400	59,649	4.79
*KD300XP0	30.000	31.000	30.370	30.630	20,860	6,856	52,160	12,600	318,100	78,447	5.73

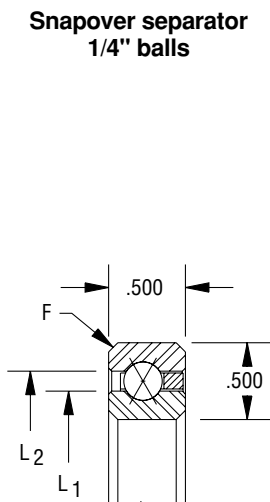

③ F = .060
Bearing corners are normally chamfered

① Capacities listed are not simultaneous. For combined loading see discussion of Bearing Selection and Load Analysis. Dynamic capacities are based upon 1 million revolutions of L10 life. Published capacities do not apply to hybrid series bearings P, X, and Y - contact KAYDON product engineering for values.
 ② Static capacities are non-brinell limits based on rigid support from the shaft and housing.
 ③ "F" is the maximum shaft or housing fillet radius the bearing corners will clear.
 * Contact KAYDON for lead time and minimum purchase requirement.

TYPE X - OPEN REALI-SLIM® BEARINGS, FOUR-POINT CONTACT

Section 2-Selection Tables

KF SERIES											
KAYDON Bearing Number	Dimensions in Inches				Capacities ^①						Weight in Pounds
	Bore	Outside Dia.	Land Dia. L ₁	Land Dia. L ₂	Radial (lbs)		Thrust (lbs)		Moment (in-lbs)		
					Static ^②	Dyn.	Static ^②	Dyn.	Static ^②	Dyn.	
KF040XP0	4.000	5.500	4.555	4.945	5,360	4,665	13,400	6,830	12,730	8,312	1.9
KF042XP0	4.250	5.750	4.805	5.195	5,640	4,795	14,110	7,070	14,110	8,993	2.0
KF045XP0	4.500	6.000	5.055	5.445	5,930	4,923	14,810	7,300	15,550	9,695	2.1
KF047XP0	4.750	6.250	5.305	5.695	6,210	5,048	15,520	7,530	17,070	10,416	2.2
KF050XP0	5.000	6.500	5.555	5.945	6,490	5,172	16,220	7,760	18,660	11,157	2.3
KF055XP0	5.500	7.000	6.055	6.445	7,050	5,415	17,630	8,200	22,040	12,696	2.5
KF060XP0	6.000	7.500	6.555	6.945	7,620	5,651	19,050	8,630	25,710	14,311	2.7
KF065XP0	6.500	8.000	7.055	7.445	8,180	5,880	20,460	9,050	29,660	15,993	2.9
KF070XP0	7.000	8.500	7.555	7.945	8,750	6,103	21,870	9,460	33,890	17,744	3.2
KF075XP0	7.500	9.000	8.055	8.445	9,310	6,323	23,280	9,870	38,410	19,568	3.4
KF080XP0	8.000	9.500	8.555	8.945	9,880	6,535	24,690	10,260	43,200	21,453	3.5
KF090XP0	9.000	10.500	9.555	9.945	11,000	6,947	27,510	11,030	53,640	25,410	3.9
KF100XP0	10.000	11.500	10.555	10.945	12,130	7,342	30,330	11,770	65,210	29,608	4.3
KF110XP0	11.000	12.500	11.555	11.945	13,260	7,721	33,150	12,490	77,910	34,032	4.8
KF120XP0	12.000	13.500	12.555	12.945	14,390	8,084	35,970	13,190	91,730	38,666	5.2
KF140XP0	14.000	15.500	14.555	14.945	16,650	8,775	41,620	14,530	122,800	48,556	6.0
*KF160XP0	16.000	17.500	16.555	16.945	18,900	9,421	47,260	15,820	158,300	59,200	7.1
*KF180XP0	18.000	19.500	18.555	18.945	21,160	10,028	52,900	17,060	198,400	70,537	7.9
*KF200XP0	20.000	21.500	20.555	20.945	23,420	10,602	58,550	18,250	243,000	82,528	8.9
*KF250XP0	25.000	26.500	25.555	25.945	29,060	11,909	72,650	21,070	374,200	115,037	10.9
*KF300XP0	30.000	31.500	30.555	30.945	34,700	13,065	86,760	23,720	533,600	150,708	13.0
*KF350XP0	35.000	36.500	35.555	35.945	40,350	14,100	100,900	26,220	721,200	189,106	15.1
*KF400XP0	40.000	41.500	40.555	40.945	45,990	15,034	115,000	28,620	937,100	229,832	17.2

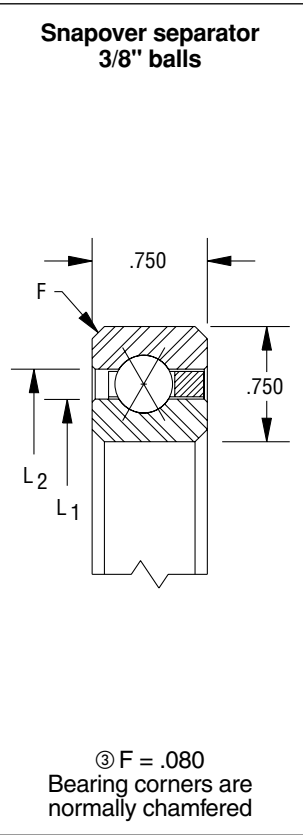

KG SERIES											
KAYDON Bearing Number	Dimensions in Inches				Capacities ^①						Weight in Pounds
	Bore	Outside Dia.	Land Dia. L ₁	Land Dia. L ₂	Radial (lbs)		Thrust (lbs)		Moment (in-lbs)		
					Static ^②	Dyn.	Static ^②	Dyn.	Static ^②	Dyn.	
*KG040XP0	4.000	6.000	4.742	5.258	8,210	7,979	20,520	11,260	20,520	14,966	3.6
*KG042XP0	4.250	6.250	4.992	5.508	8,210	7,917	20,520	11,260	21,550	15,592	3.8
*KG045XP0	4.500	6.500	5.242	5.758	8,760	8,205	21,890	11,750	24,080	16,930	4.0
*KG047XP0	4.750	6.750	5.492	6.008	9,300	8,487	23,260	12,230	26,740	18,306	4.1
KG050XP0	5.000	7.000	5.742	6.258	9,850	8,762	24,620	12,710	29,550	19,721	4.3
*KG055XP0	5.500	7.500	6.242	6.758	10,400	8,979	25,990	13,180	33,790	21,896	4.7
KG060XP0	6.000	8.000	6.742	7.258	11,490	9,503	28,730	14,090	40,220	24,956	5.1
*KG065XP0	6.500	8.500	7.242	7.758	12,040	9,713	30,100	14,530	45,140	27,327	5.4
*KG070XP0	7.000	9.000	7.742	8.258	13,130	10,208	32,830	15,400	52,530	30,636	5.8
KG075XP0	7.500	9.500	8.242	8.758	13,680	10,410	34,200	15,820	58,140	33,196	6.1
KG080XP0	8.000	10.000	8.742	9.258	14,770	10,882	36,940	16,650	66,480	36,743	6.5
KG090XP0	9.000	11.000	9.742	10.258	16,420	11,526	41,040	17,870	82,080	43,240	7.2
KG100XP0	10.000	12.000	10.742	11.258	18,060	12,147	45,140	19,040	99,320	50,124	7.9
KG110XP0	11.000	13.000	11.742	12.258	19,700	12,739	49,250	20,180	118,200	57,347	8.6
KG120XP0	12.000	14.000	12.742	13.258	21,340	13,315	53,350	21,280	138,700	64,935	9.3
KG140XP0	14.000	16.000	14.742	15.258	24,620	14,404	61,560	23,410	184,700	81,056	10.8
KG160XP0	16.000	18.000	16.742	17.258	27,910	15,425	69,770	25,450	237,200	98,373	12.3
KG180XP0	18.000	20.000	18.742	19.258	31,190	16,386	77,980	27,410	296,300	116,793	13.7
KG200XP0	20.000	22.000	20.742	21.258	34,470	17,293	86,180	29,300	362,000	136,238	15.8
KG220XP0	22.000	24.000	22.742	23.258	37,760	18,152	94,390	31,130	434,200	156,625	17.3
KG250XP0	25.000	27.000	25.742	26.258	42,680	19,360	106,700	33,780	554,900	188,838	19.5
KG300XP0	30.000	32.000	30.742	31.258	50,890	21,200	127,200	37,980	788,800	246,541	23.3
KG350XP0	35.000	37.000	35.742	36.258	59,100	22,845	147,700	41,970	1,064,000	308,527	27.1
KG400XP0	40.000	42.000	40.742	41.258	67,310	24,332	168,300	45,770	1,380,000	374,256	30.8

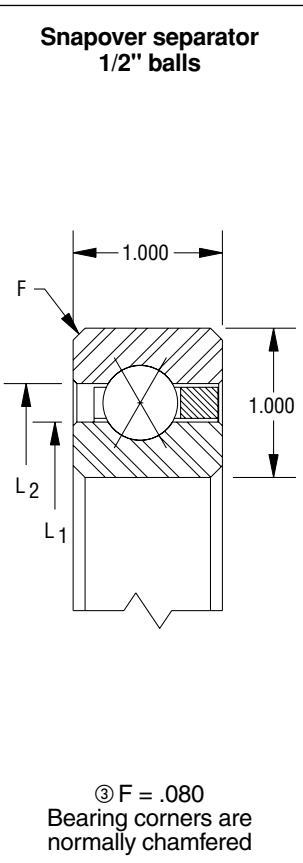

① Capacities listed are not simultaneous. For combined loading see discussion of Bearing Selection and Load Analysis. Dynamic capacities are based upon 1 million revolutions of L10 life. Published capacities do not apply to hybrid series bearings P, X, and Y - contact KAYDON product engineering for values.
 ② Static capacities are non-brinell limits based on rigid support from the shaft and housing.
 ③ "F" is the maximum shaft or housing fillet radius the bearing corners will clear.
 * Contact KAYDON for lead time and minimum purchase requirement.

Sealed REALI-SLIM® Bearing Selections

Seals and Shields Available

To realize the full benefits from anti-friction bearings, it is important to keep them clean and well lubricated. Seals and shields properly designed and mounted help to accomplish this. In this catalog these terms have the following definitions:

Seal—a contacting closure between the stationary and rotating members, for retaining lubricant within and excluding foreign material from the bearing. Seals are retained in the outer race and make positive contact with the inner race.

Shield—a closure for the same purpose as a seal but without positive contact.

A seal is more effective, but requires more turning effort (torque), generates more heat, and as a result, has a lower speed limit than an open or shielded bearing.

The accompanying illustrations are examples by which REALI-SLIM® bearings may be sealed or shielded, either integrally or externally. The lubricant and lubrication systems, torque requirements, speed, and operating environment will influence the choice.

Integral seals and shields offer a very compact overall design with the additional advantage of protecting the bearing before, during and after installation.

Figure 2-1 shows a double-sealed REALI-SLIM® bearing, available from stock in the JU series. In this case, adding shields and seals requires an increase in the width of the bearing (see page 12, Position 2). In the case of JA, JB, and JG double-sealed REALI-SLIM® bearings, the bearing width is the same as that of the open bearing.

Illustrated in Figure 2-2 is a double LAMI-SEAL® bearing. Shown in Figure 2-3 is a double LAMI-SHIELD® bearing for use where a shield will suffice or is required due to torque limitations or speed.

Where weight and space are at a premium, and a seal or shield is required on one side only, single-sealed or single-shielded bearings as shown in Figures 2-4, 2-5 and 2-6 may be supplied.

Note: Sealed REALI-SLIM® bearings are pre-lubricated with a general purpose grease. Operating conditions (i.e. time, temperature, speed, environment) may result in premature lubrication degradation. A variety of lubricants are available as options to meet your specifications.

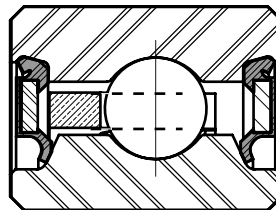

Figure 2-1
Double-Sealed REALI-SLIM® bearing

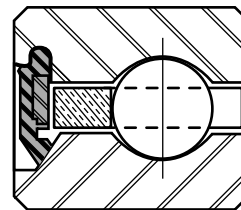

Figure 2-4
Single-Sealed REALI-SLIM® bearing

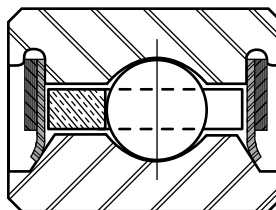

Figure 2-2
Double LAMI-SEAL® bearing

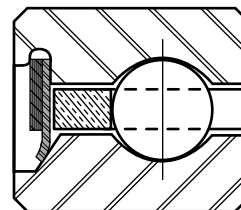

Figure 2-5
Single LAMI-SEAL® bearing

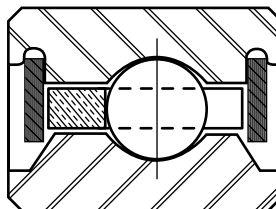

Figure 2-3
Double LAMI-SHIELD® bearing

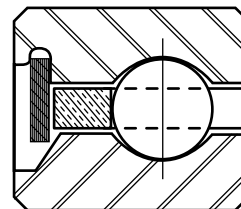

Figure 2-6
Single LAMI-SHIELD® bearing

Note: Pictures are for illustration only and are not intended for design specification.

SEALED REALI-SLIM® BEARINGS, SEALS AND SHIELDS (continued)

Figure 2-7 shows a nitrile lip-type seal ring available in a variety of cross-sections compatible with the REALI-SLIM® bearing series. While this is a very effective seal, torque is substantial and speeds must not exceed 1000 feet per minute if continuous.

If grease lubrication is used and torque is not critical, a very effective shield is that shown in Figure 2-8 where annular grooves are cut in the housing shoulder and clamp plate and filled with grease.

When a separate shield is required, washers made from precision flat stock are ideal, as shown in Figure 2-9. They serve well where weight limitations are strict.

Whether or not integral seals or shields are specified, bearings must be isolated from hostile environments and debris.

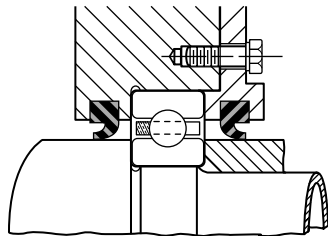

Figure 2-7
Nitrile Lip-Type Seal

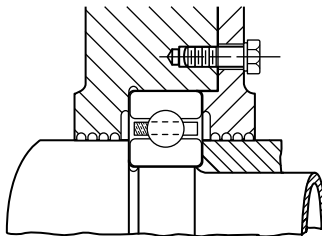

Figure 2-8
Annular Grooves

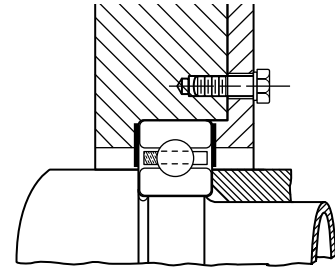

Figure 2-9
Washer Shield From
Precision Flat Stock

Sealed REALI-SLIM® Bearing Selections

Type C Radial Contact

JHA SERIES (DOUBLE SEALED)									
KAYDON Bearing Number	Dimensions in Inches				Radial Capacity (lbs.) ^①		Limiting Speeds (RPM ^{**})	Torque Max. No Load (in-oz) ^④	Weight in Pounds
	Bore	Outside Dia.	Land Dia. L ₁	Land Dia. L ₂	Static ^②	Dyn.			
JHA10CL0	1.000	1.375	1.108	1.274	290	188	6110	5	.035
JHA15CL0	1.500	1.875	1.608	1.774	400	225	4300	5	.052
JHA17CL0	1.750	2.125	1.858	2.024	460	242	3750	6	.060

Snapover separator 3/32" balls

③ F = .015
Bearing corners are normally chamfered

JA SERIES (DOUBLE SEALED)									
KAYDON Bearing Number	Dimensions in Inches				Radial Capacity (lbs.) ^①		Limiting Speeds (RPM ^{**})	Torque Max. No Load (in-oz) ^④	Weight in Pounds
	Bore	Outside Dia.	Land Dia. L ₁	Land Dia. L ₂	Static ^②	Dyn.			
JA020CP0	2.000	2.500	2.148	2.356	680	393	3,220	6	.10
JA025CP0	2.500	3.000	2.648	2.856	830	442	2,630	8	.12
JA030CP0	3.000	3.500	3.148	3.356	990	487	2,230	12	.14
JA035CP0	3.500	4.000	3.648	3.856	1,140	530	1,930	16	.17
JA040CP0	4.000	4.500	4.148	4.356	1,290	571	1,700	20	.19
JA042CP0	4.250	4.750	4.398	4.606	1,370	591	1,610	24	.20
JA045CP0	4.500	5.000	4.648	4.856	1,440	610	1,520	28	.21
*JA047CP0	4.750	5.250	4.898	5.106	1,520	629	1,450	32	.22
JA050CP0	5.000	5.500	5.148	5.356	1,590	648	1,380	36	.23
*JA055CP0	5.500	6.000	5.648	5.856	1,750	685	1,260	44	.25
*JA060CP0	6.000	6.500	6.148	6.356	1,900	720	1,160	52	.28
*JA065CP0	6.500	7.000	6.648	6.856	2,050	754	1,070	61	.30

Snapover separator 1/8" balls

③ F = .025
Bearing corners are normally chamfered

① Capacities listed are not simultaneous. For combined loading see discussion of Bearing Selection and Load Analysis. Dynamic capacities are based upon 1 million revolutions of L10 life. Published capacities do not apply to hybrid series bearings P, X, and Y - contact KAYDON product engineering for values.

② Static capacities are non-brinell limits based on rigid support from the shaft and housing.

③ "F" is the maximum shaft or housing fillet radius the bearing corners will clear.

④ Torque figures shown are for single bearings with standard lubricant at room temperature and under 5 pounds thrust load.

** Values apply to bearings loaded up to 20% of their dynamic capacity.

* Contact KAYDON for lead time and minimum purchase requirement.

TYPE C - SEALED REALI-SLIM® BEARINGS, RADIAL CONTACT

Section 2-Selection Tables

JB SERIES (DOUBLE SEALED)									
KAYDON Bearing Number	Dimensions in Inches				Radial Capacity (lbs.) ^①		Limiting Speeds (RPM ^{**})	Torque Max. No Load (in-oz) ^④	Weight in Pounds
	Bore	Outside Dia.	Land Dia. L ₁	Land Dia. L ₂	Static ^②	Dyn.			
JB020CP0	2.000	2.625	2.199	2.425	930	577	3,130	6	.15
JB025CP0	2.500	3.125	2.699	2.925	1,140	644	2,580	8	.19
JB030CP0	3.000	3.625	3.199	3.425	1,340	707	2,190	12	.22
JB035CP0	3.500	4.125	3.699	3.925	1,540	767	1,900	16	.27
JB040CP0	4.000	4.625	4.199	4.425	1,750	825	1,630	20	.30
JB042CP0	4.250	4.875	4.449	4.675	1,830	846	1,600	24	.31
JB045CP0	4.500	5.125	4.699	4.925	1,950	880	1,500	28	.34
*JB047CP0	4.750	5.375	4.949	5.175	2,030	901	1,430	32	.35
*JB050CP0	5.000	5.625	5.199	5.425	2,150	933	1,360	36	.37
*JB055CP0	5.500	6.125	5.699	5.925	2,360	984	1,240	44	.40
*JB060CP0	6.000	6.625	6.199	6.425	2,560	1,034	1,150	52	.44
*JB065CP0	6.500	7.125	6.699	6.925	2,760	1,082	1,060	61	.47

Snapover separator 5/32" balls

③ F = .040
Bearing corners are normally chamfered

JU SERIES (DOUBLE SEALED)									
KAYDON Bearing Number	Dimensions in Inches				Radial Capacity (lbs.) ^①		Limiting Speeds (RPM ^{**})	Torque Max. No Load (in-lb) ^④	Weight in Pounds
	Bore	Outside Dia.	Land Dia. L ₁	Land Dia. L ₂	Static ^②	Dyn.			
JU040CP0	4.000	4.750	4.150	4.547	2,100	1,073	1,640	2.9	.55
JU042CP0	4.250	5.000	4.400	4.797	2,220	1,108	1,520	3.2	.58
JU045CP0	4.500	5.250	4.650	5.047	2,340	1,143	1,440	3.5	.61
JU047CP0	4.750	5.500	4.900	5.295	2,460	1,176	1,360	3.9	.65
JU050CP0	5.000	5.750	5.150	5.545	2,590	1,209	1,300	4.3	.68
JU055CP0	5.500	6.250	5.650	6.042	2,830	1,274	1,180	5.1	.74
JU060CP0	6.000	6.750	6.150	6.542	3,070	1,337	1,080	6.1	.81
JU065CP0	6.500	7.250	6.650	7.037	3,315	1,397	1,000	7.0	.87
JU070CP0	7.000	7.750	7.150	7.537	3,550	1,457	920	8.1	.93
JU075CP0	7.500	8.250	7.650	8.037	3,790	1,514	860	9.2	.99
JU080CP0	8.000	8.750	8.150	8.537	4,030	1,570	810	10.4	1.06
JU090CP0	9.000	9.750	9.150	9.535	4,510	1,678	720	13.0	1.18
JU100CP0	10.000	10.750	10.150	10.535	4,990	1,781	650	16.0	1.31
JU110CP0	11.000	11.750	11.150	11.535	5,470	1,879	590	19.2	1.43
JU120CP0	12.000	12.750	12.150	12.535	5,950	1,974	540	22.8	1.56

Snapover separator 3/16" balls

③ F = .015
Bearing corners are normally chamfered

① Capacities listed are not simultaneous. For combined loading see discussion of Bearing Selection and Load Analysis. Dynamic capacities are based upon 1 million revolutions of L10 life. Published capacities do not apply to hybrid series bearings P, X, and Y - contact KAYDON product engineering for values.

② Static capacities are non-brinell limits based on rigid support from the shaft and housing.

③ "F" is the maximum shaft or housing fillet radius the bearing corners will clear.

④ Torque figures shown are for single bearings with standard lubricant at room temperature and under 5 pounds thrust load.

** Values apply to bearings loaded up to 20% of their dynamic capacity.

* Contact KAYDON for lead time and minimum purchase requirement.

TYPE C - SEALED REALI-SLIM® BEARINGS, RADIAL CONTACT

JG SERIES (DOUBLE SEALED)										
KAYDON Bearing Number	Dimensions in Inches				Radial Capacity (lbs.) ^①		Limiting Speeds (RPM ^{**})	Torque Max. No Load (in-lb) ^④	Weight in Pounds	
	Bore	Outside Dia.	Land Dia. L ₁	Land Dia. L ₂	Static ^②	Dyn.				
*JG120CP0	12.000	14.000	12.554	13.602	21,340	10,074	140	44	9.3	③ F = .080 Bearing corners are normally chamfered
*JG140CP0	14.000	16.000	14.554	15.602	24,620	10,886	125	59	10.8	
*JG160CP0	16.000	18.000	16.554	17.602	27,910	11,648	110	76	12.3	
*JG180CP0	18.000	20.000	18.554	19.602	31,190	12,367	100	95	13.7	
*JG200CP0	20.000	22.000	20.554	21.602	34,470	13,044	90	115	15.8	
*JG220CP0	22.000	24.000	22.554	23.602	37,760	13,685	80	139	16.8	
*JG250CP0	25.000	27.000	25.554	26.602	42,680	14,591	75	177	19.5	
*JG300CP0	30.000	32.000	30.554	31.602	50,890	15,963	60	252	23.3	
*JG350CP0	35.000	37.000	35.554	36.602	59,100	17,195	55	339	27.1	
*JG400CP0	40.000	42.000	40.554	41.602	67,310	18,307	50	440	30.8	

- ① Capacities listed are not simultaneous. For combined loading see discussion of Bearing Selection and Load Analysis. Dynamic capacities are based upon 1 million revolutions of L10 life. Published capacities do not apply to hybrid series bearings P, X, and Y - contact KAYDON product engineering for values.
- ② Static capacities are non-brinell limits based on rigid support from the shaft and housing.
- ③ "F" is the maximum shaft or housing fillet radius the bearing corners will clear.
- ④ Torque figures shown are for single bearings with standard lubricant at room temperature and under 5 pounds thrust load.
- ** Values apply to bearings loaded up to 20% of their dynamic capacity.
- * Contact KAYDON for lead time and minimum purchase requirement.

CONTACT KAYDON AT—
 KAYDON Corporation • Muskegon, Michigan 49443
 Telephone: 231/755-3741 • Fax: 231/759-4102

NEED SERVICE FAST?
 1-800-514-3066
 Website: www.kaydonbearings.com

Sealed REALI-SLIM® Bearing Selections

Type X

Four-Point Contact

JHA SERIES (DOUBLE SEALED)													
KAYDON Bearing Number	Dimensions in Inches				Capacities ^①						Limiting Speeds (RPM ^{**})	Torque Max. No Load (in-oz) ^④	Weight in Pounds
	Bore	Outside Dia.	Land Dia. L ₁	Land Dia. L ₂	Radial (lbs)		Thrust (lbs)		Moment (in-lbs)				
					Static ^②	Dyn.	Static ^②	Dyn.	Static ^②	Dyn.			
JHA10XL0	1.000	1.375	1.108	1.274	290	247	730	370	170	110	3,000	5	.035
JHA15XL0	1.500	1.875	1.608	1.774	400	296	1,000	460	340	187	2,000	5	.052
JHA17XL0	1.750	2.125	1.858	2.024	460	319	1,140	500	440	232	1,710	6	.060

Snapover separator 3/32" balls

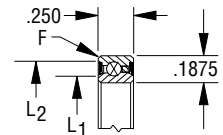

③ F = .015
Bearing corners are normally chamfered

JA SERIES (DOUBLE SEALED)													
KAYDON Bearing Number	Dimensions in Inches				Capacities ^①						Limiting Speeds (RPM ^{**})	Torque Max. No Load (in-oz) ^④	Weight in Pounds
	Bore	Outside Dia.	Land Dia. L ₁	Land Dia. L ₂	Radial (lbs)		Thrust (lbs)		Moment (in-lbs)				
					Static ^②	Dyn.	Static ^②	Dyn.	Static ^②	Dyn.			
JA020XP0	2.000	2.500	2.148	2.356	680	514	1,710	790	770	434	1,500	6	.10
JA025XP0	2.500	3.000	2.648	2.856	830	583	2,090	910	1,150	601	1,200	8	.12
JA030XP0	3.000	3.500	3.148	3.356	990	643	2,470	1,010	1,600	785	830	12	.14
JA035XP0	3.500	4.000	3.648	3.856	1,140	701	2,850	1,110	2,130	986	710	16	.17
JA040XP0	4.000	4.500	4.148	4.356	1,290	756	3,220	1,210	2,740	1,205	620	20	.19
JA042XP0	4.250	4.750	4.398	4.606	1,370	783	3,410	1,260	3,070	1,321	580	24	.20
JA045XP0	4.500	5.000	4.648	4.856	1,440	809	3,600	1,310	3,420	1,441	550	28	.21
*JA047XP0	4.750	5.250	4.898	5.106	1,520	834	3,790	1,350	3,790	1,565	520	32	.22
*JA050XP0	5.000	5.500	5.148	5.356	1,590	859	3,980	1,400	4,180	1,693	500	36	.23
*JA055XP0	5.500	6.000	5.648	5.856	1,750	908	4,360	1,480	5,020	1,959	450	44	.25
*JA060XP0	6.000	6.500	6.148	6.356	1,900	955	4,740	1,570	5,930	2,240	330	52	.28
*JA065XP0	6.500	7.000	6.648	6.856	2,050	1,001	5,120	1,650	6,910	2,535	300	61	.30

Snapover separator 1/8" balls

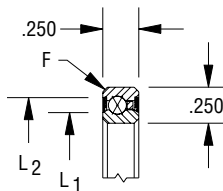

③ F = .025
Bearing corners are normally chamfered

① Capacities listed are not simultaneous. For combined loading see discussion of Bearing Selection and Load Analysis. Dynamic capacities are based upon 1 million revolutions of L10 life. Published capacities do not apply to hybrid series bearings P, X, and Y - contact KAYDON product engineering for values.

② Static capacities are non-brinell limits based on rigid support from the shaft and housing.

③ "F" is the maximum shaft or housing fillet radius the bearing corners will clear.

④ Torque figures shown are for single bearings with standard lubricant at room temperature and under 5 pounds thrust load.

** Values apply to bearings loaded up to 20% of their dynamic capacity.

* Contact KAYDON for lead time and minimum purchase requirement.

TYPE X - SEALED REALI-SLIM® BEARINGS, FOUR-POINT CONTACT

JB SERIES (DOUBLE SEALED)													
KAYDON Bearing Number	Dimensions in Inches				Capacities ^①						Limiting Speeds (RPM ^{**})	Torque Max. No Load (in-oz) ^③	Weight in Pounds
	Bore	Outside Dia.	Land Dia. L ₁	Land Dia. L ₂	Radial (lbs)		Thrust (lbs)		Moment (in-lbs)				
					Static ^②	Dyn.	Static ^②	Dyn.	Static ^②	Dyn.			
JB020XP0	2.000	2.625	2.199	2.425	930	758	2,340	1,130	1,080	658	1,500	6	.15
JB025XP0	2.500	3.125	2.699	2.925	1,140	848	2,840	1,290	1,600	895	1,200	8	.19
JB030XP0	3.000	3.625	3.199	3.425	1,340	933	3,350	1,440	2,220	1,159	1,000	12	.22
JB035XP0	3.500	4.125	3.699	3.925	1,540	1,014	3,860	1,590	2,940	1,450	710	16	.27
JB040XP0	4.000	4.625	4.199	4.425	1,750	1,091	4,370	1,720	3,770	1,764	620	20	.30
JB042XP0	4.250	4.875	4.449	4.675	1,830	1,120	4,570	1,780	4,170	1,917	590	24	.31
JB045XP0	4.500	5.125	4.699	4.925	1,950	1,165	4,880	1,850	4,690	2,103	550	28	.34
*JB047XP0	4.750	5.375	4.949	5.175	2,030	1,193	5,080	1,900	5,140	2,265	520	32	.35
*JB050XP0	5.000	5.625	5.199	5.425	2,150	1,236	5,380	1,980	5,720	2,463	500	36	.37
*JB055XP0	5.500	6.125	5.699	5.925	2,360	1,304	5,890	2,100	6,850	2,844	450	44	.40
*JB060XP0	6.000	6.625	6.199	6.425	2,560	1,371	6,400	2,220	8,080	3,247	410	52	.44
*JB065XP0	6.500	7.125	6.699	6.925	2,760	1,435	6,910	2,340	9,410	3,668	380	61	.47

Snapover separator
5/32" balls

③ F = .040
Bearing corners are normally chamfered

JU SERIES (DOUBLE SEALED)													
KAYDON Bearing Number	Dimensions in Inches				Capacities ^①						Limiting Speeds (RPM ^{**})	Torque Max. No Load (in-lb) ^③	Weight in Pounds
	Bore	Outside Dia.	Land Dia. L ₁	Land Dia. L ₂	Radial (lbs)		Thrust (lbs)		Moment (in-lbs)				
					Static ^②	Dyn.	Static ^②	Dyn.	Static ^②	Dyn.			
JU040XP0	4.000	4.750	4.150	4.547	2,100	1,417	5,260	2,210	4,600	2,326	620	2.9	.55
JU042XP0	4.250	5.000	4.400	4.797	2,220	1,464	5,560	2,290	5,140	2,541	590	3.2	.58
JU045XP0	4.500	5.250	4.650	5.047	2,340	1,510	5,860	2,380	5,710	2,762	550	3.5	.61
JU047XP0	4.750	5.500	4.900	5.295	2,460	1,556	6,160	2,460	6,320	2,991	520	3.9	.65
JU050XP0	5.000	5.750	5.150	5.545	2,590	1,600	6,460	2,540	6,950	3,226	500	4.3	.68
JU055XP0	5.500	6.250	5.650	6.042	2,830	1,687	7,060	2,690	8,300	3,717	450	5.1	.74
JU060XP0	6.000	6.750	6.150	6.542	3,070	1,770	7,660	2,840	9,770	4,234	410	6.1	.81
JU065XP0	6.500	7.250	6.650	7.037	3,310	1,851	8,270	2,990	11,370	4,775	380	7.0	.87
JU070XP0	7.000	7.750	7.150	7.537	3,550	1,931	8,870	3,130	13,080	5,341	350	8.1	.93
JU075XP0	7.500	8.250	7.650	8.037	3,790	2,007	9,470	3,270	14,910	5,930	330	9.2	.99
JU080XP0	8.000	8.750	8.150	8.537	4,030	2,082	10,070	3,410	16,870	6,542	310	10.4	1.06
JU090XP0	9.000	9.750	9.150	9.535	4,510	2,226	11,270	3,670	21,130	7,830	220	13.0	1.18
JU100XP0	10.000	10.750	10.150	10.535	4,990	2,364	12,470	3,930	25,880	9,201	200	16.0	1.31
JU110XP0	11.000	11.750	11.150	11.535	5,470	2,496	13,680	4,180	31,110	10,651	180	19.2	1.43
JU120XP0	12.000	12.750	12.150	12.535	5,950	2,622	14,880	4,420	36,830	12,174	160	22.8	1.56

Snapover separator
3/16" balls

③ F = .015
Bearing corners are normally chamfered

① Capacities listed are not simultaneous. For combined loading see discussion of Bearing Selection and Load Analysis. Dynamic capacities are based upon 1 million revolutions of L10 life. Published capacities do not apply to hybrid series bearings P, X, and Y - contact KAYDON product engineering for values.

② Static capacities are non-brinell limits based on rigid support from the shaft and housing.

③ "F" is the maximum shaft or housing fillet radius the bearing corners will clear.

④ Torque figures shown are single bearings with standard lubricant at room temperature and under 5 pound thrust load.

** Values apply to bearings loaded up to 20% of their dynamic capacity.

* Contact KAYDON for lead time and minimum purchase requirement.

TYPE X - SEALED REALI-SLIM® BEARINGS, FOUR-POINT CONTACT

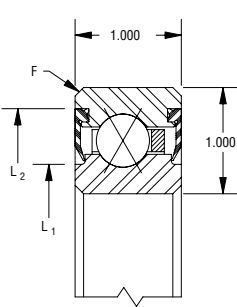
JG SERIES													Snapover separator 1/2" balls 	
KAYDON Bearing Number	Dimensions in Inches				Capacities ^①						Limiting Speeds (RPM ^{**})	Torque Max. No Load (in-lb) ^④		Weight in Pounds
	Bore	Outside Dia.	Land Dia. L ₁	Land Dia. L ₂	Radial (lbs)		Thrust (lbs)		Moment (in-lbs)					
					Static ^②	Dyn.	Static ^②	Dyn.	Static ^②	Dyn.				
*JG120XP0	12.000	14.000	12.554	13.602	21,340	13,315	53,350	21,280	138,700	64,935	140	44	9.3	
*JG140XP0	14.000	16.000	14.554	15.602	24,620	14,404	61,560	34,410	184,700	81,056	125	59	10.8	
*JG160XP0	16.000	18.000	16.554	17.602	27,910	15,425	69,770	25,450	237,200	98,373	110	76	12.3	
*JG180XP0	18.000	20.000	18.554	19.602	31,190	16,386	77,980	27,410	296,300	116,793	100	95	13.7	
*JG200XP0	20.000	22.000	20.554	21.602	34,470	17,293	86,180	29,300	362,000	136,238	90	115	15.8	
*JG220XP0	22.000	24.000	22.554	23.602	37,750	18,152	94,390	31,130	434,200	156,625	80	138	16.8	
*JG250XP0	25.000	27.000	25.554	26.602	42,680	19,360	106,700	33,780	554,900	188,838	75	177	19.5	
*JG300XP0	30.000	32.000	30.554	31.602	50,890	21,200	127,200	37,980	788,800	246,541	60	252	23.3	
*JG350XP0	35.000	37.000	35.554	36.602	59,100	22,845	147,700	41,970	1,064,000	308,527	55	339	27.1	
*JG400XP0	40.000	42.000	40.554	41.602	63,310	24,332	168,300	45,770	1,380,000	374,256	50	440	30.8	

① Capacities listed are not simultaneous. For combined loading see discussion of Bearing Selection and Load Analysis. Dynamic capacities are based upon 1 million revolutions of L10 life. Published capacities do not apply to hybrid series bearings P, X, and Y - contact KAYDON product engineering for values.
 ② Static capacities are non-brinell limits based on rigid support from the shaft and housing.
 ③ "F" is the maximum shaft or housing fillet radius the bearing corners will clear.
 ④ Torque figures shown are for single bearings with standard lubricant at room temperature and under 5 pounds thrust load.
 ** Values apply to bearings loaded up to 20% of their dynamic capacity.
 * Contact KAYDON for lead time and minimum purchase requirement.

CONTACT KAYDON AT—
 KAYDON Corporation • Muskegon, Michigan 49443
 Telephone: 231/755-3741 • Fax: 231/759-4102
NEED SERVICE FAST?
 1-800-514-3066
 Website: www.kaydonbearings.com

ENDURAKOTE® Plating for Corrosion-Resistant Bearings (Series L, N)

Introduction

ENDURAKOTE® plating protects bearings from corrosion and provides substantial life improvements in hostile environments. ENDURAKOTE® plating is applied over conventional bearing materials such as AISI 52100 steel, and offers the benefit of corrosion resistance normally found only in stainless steel bearings. The coating is applied to each entire bearing race ring, including the paths, thus leaving no area exposed. Other commercial chrome or cadmium coatings normally accepted and used cannot be applied to the path due to the rolling contact stresses. ENDURAKOTE® plating is hard chromium, electrodeposited by a proprietary process which achieves a true molecular bond, and will not flake or peel even under the high contact stresses experienced in the bearing paths.

Laboratory and field testing results have proven the benefits of this process. Severe salt spray testing has shown that bearings with ENDURAKOTE® plating withstand corrosion as well as or better than AISI 440C stainless steel. The hard, dense exterior surface formed by the coating is extremely wear resistant and is excellent in the retention of the lubricant film. Conventional life testing of AISI 52100 steel bearings with ENDURAKOTE® plating has shown that no life de-rating is necessary. In fact, the extremely hard surface of ENDURAKOTE® plating protects the bearing from surface generated damage which can promote premature failure. Since the coating is capable of withstanding extremely high temperatures, the bearings are limited by the bearing materials or lubricant used.

The coating used for ENDURAKOTE® plating can be applied to any type of bearing and to most bearing materials. Its primary advantage is to utilize stock materials such as AISI 52100, etc. with their economies, and convert them to wear and corrosion resistant bearings. This is particularly beneficial for larger diameter bearings or where quick delivery is critical. Thus, cost savings can be achieved over more exotic or specialized materials. Also, stock bearings can have ENDURAKOTE® plating applied for quick delivery.

The net result is that we can offer bearings with the capacity of conventional bearing steels and the corrosion resistance of AISI 440C stainless steel from standard AISI 52100 stock components.

Application

ENDURAKOTE® plating provides corrosion resistance and is effective in increasing wear resistance in sliding surface contacts such as the lands where the cage pilots. The micro-surface composition of ENDURAKOTE® plating aids in lubricant dispersion, enhancing base metals to the degree of reducing or eliminating galling, seizing, and high friction, over a wide range of installations and environments.

Advantages

ENDURAKOTE® plating effects a buildup of less than .0002 under normal circumstances. Thus, it can often be applied to stock bearing components which have been specially selected. ENDURAKOTE® plating is compatible with most ferrous and nonferrous metal, allowing maximum flexibility in selection of base material. ENDURAKOTE® plating is normally a final process, and its quality is constant with any given base metal, insuring design reproducibility.

Properties and Characteristics

A. Hardness

ENDURAKOTE® plating, as deposited, has an equivalent hardness in excess of 70 Rockwell "C." When measured by conventional micro-hardness methods, the host material will modify this measurement to some degree.

B. Coefficient of Friction

(Note: Measurements made at 72°F, using other materials for comparison.)

Material	Against Material	Static	—	Sliding
Steel	Steel	0.30	—	0.20
Steel	Brass, Bronze	0.25	—	0.20
Steel	ENDURAKOTE® plating	0.17	—	0.16
Brass, Bronze	ENDURAKOTE® plating	0.15	—	0.13
ENDURAKOTE® plating	ENDURAKOTE® plating	0.14	—	0.12

ENDURAKOTE® Plating (continued)**C. Adhesion**

ENDURAKOTE® plating will not flake, crack, chip, peel or otherwise separate from the base material under standard bend tests or under conditions where severe heat is induced. The adherence is adequate to withstand the extremely high compressive stresses in the contact areas of ball and roller bearings.

D. Effect On Base

The purity of the chromium surface will not be less than 99% as deposited. A comprehensive testing program at KAYDON established that bearings with ENDURAKOTE® plating exhibited load carrying capacities and life expectancy equal to or better than uncoated AISI 52100 steel bearings.

E. Corrosion Resistance

ENDURAKOTE® plating resists attack by most organic and inorganic compounds with a pH within the range of 4 and 11, except sulfuric and hydrochloric acids. Porosity of the base metal, compound concentration and exposure time to the compound become corrosion factors, but ENDURAKOTE® plating greatly enhances the base material. In severe salt spray tests as well as tap water immersion tests, AISI 52100 steel with ENDURAKOTE® plating proved equal to fully hardened AISI 440C stainless steel in resistance to rusting. In many instances, ENDURAKOTE® plating is better for corrosion protection than cadmium plate, zinc plate, phosphates, chromates, black oxide or normal chrome plate. We invite inquiries about and will be pleased to arrange tests to qualify ENDURAKOTE® plating for specific environments.

F. Heat Resistance

REALI-SLIM® bearings with ENDURAKOTE® plating are designed to maintain their operating characteristics over a temperature range from -65°F to 250°F.

G. Surface Quality

ENDURAKOTE® plating conforms to the texture of the existing surface. Ra finish will be improved slightly down to about 8 Ra; below 4 Ra there is little change. ENDURAKOTE® plating has a matte or micro-orange peel surface with very good lubricant retention qualities.

H. Food Industries

ENDURAKOTE® plating is used on food processing equipment.

I. Load Capacity

ENDURAKOTE® plating does not affect the static or dynamic load capacity of the bearing. These values can be found by looking up the corresponding part number starting with "K" in the standard REALI-SLIM® bearing tables.

Bearing Size Capabilities

ENDURAKOTE® plating can be applied to any REALI-SLIM® bearing.

Restrictions

KAYDON does not recommend the use of ENDURAKOTE® plating in any low torque or torque-sensitive applications.

Open ENDURAKOTE®-PLATED ENDURA-SLIM® Bearing Selections

Type A Angular Contact

A deep groove bearing with reduced shoulder on one side of inner or outer race ball path. Snapover assembly permits use of a one-piece circular pocket ring separator and greater ball complement. These bearings will accept radial load and single direction thrust load and are normally used in conjunction with another bearing of similar construction. Type A bearings require

the application of thrust to establish contact angle. Stock bearings are individual units and when purchased as such must be adjusted at installation to desired running clearance or preload. Matched sets are available. KAYDON also offers matched spacers for applications requiring extra precision.

NAA SERIES										
KAYDON Bearing Number	Dimensions in Inches					Capacities in Pounds ^①				Weight in Pounds
	Bore	Outside Dia.	Land Dia. L ₁	Land Dia. L ₂	C'Bore Dia. L ₃	Radial		Thrust		
						Static ^②	Dyn.	Static ^②	Dyn.	
NAA10AG0	1.0000	1.3752	1.140	1.235	1.274	340	194	970	450	.025
NAA15AG0	1.5000	1.8752	1.640	1.735	1.774	480	238	1,380	560	.038
NAA17AG0	1.7500	2.1252	1.890	1.985	2.024	530	251	1,520	600	.045

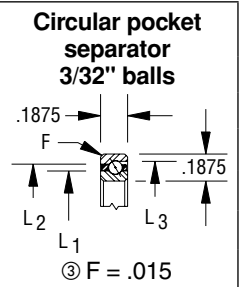

NA SERIES										
KAYDON Bearing Number	Dimensions in Inches					Capacities in Pounds ^①				Weight in Pounds
	Bore	Outside Dia.	Land Dia. L ₁	Land Dia. L ₂	C'Bore Dia. L ₃	Radial		Thrust		
						Static ^②	Dyn.	Static ^②	Dyn.	
NA020AR0	2.0000	2.5002	2.186	2.314	2.369	790	405	2,280	960	.10
NA025AR0	2.5000	3.0002	2.686	2.814	2.869	960	459	2,780	1,100	.12
NA030AR0	3.0000	3.5002	3.186	3.314	3.367	1,140	507	3,290	1,230	.14
NA035AR0	3.5000	4.0002	3.686	3.814	3.867	1,310	552	3,790	1,350	.17
NA040AR0	3.9998	4.5003	4.186	4.314	4.367	1,490	595	4,300	1,470	.19
NA042AR0	4.2498	4.7503	4.436	4.564	4.615	1,580	616	4,550	1,530	.20
NA045AR0	4.4998	5.0003	4.686	4.814	4.865	1,660	637	4,810	1,580	.21
NA047AR0	4.7498	5.2503	4.936	5.064	5.115	1,750	657	5,060	1,640	.22
NA050AR0	4.9998	5.5003	5.186	5.314	5.365	1,840	676	5,310	1,690	.23
NA055AR0	5.4998	6.0003	5.686	5.814	5.863	2,020	715	5,820	1,800	.25
NA060AR0	5.9998	6.5003	6.186	6.314	6.363	2,190	752	6,320	1,900	.28
NA065AR0	6.4998	7.0003	6.686	6.814	6.861	2,370	788	6,830	2,000	.30
NA070AR0	6.9998	7.5003	7.186	7.314	7.361	2,540	823	7,340	2,100	.32
NA075AR0	7.4998	8.0003	7.686	7.814	7.861	2,720	857	7,840	2,190	.34
*NA080AR0	7.9998	8.5003	8.186	8.314	8.359	2,890	890	8,350	2,280	.36
*NA090AR0	8.9998	9.5003	9.186	9.314	9.357	3,240	954	9,360	2,470	.41
NA100AR0	9.9998	10.5003	10.186	10.314	10.355	3,590	1,014	10,370	2,640	.45
*NA110AR0	10.9998	11.5003	11.186	11.314	11.353	3,940	1,072	11,380	2,810	.50
*NA120AR0	11.9998	12.5003	12.186	12.314	12.349	4,290	1,128	12,390	2,970	.54

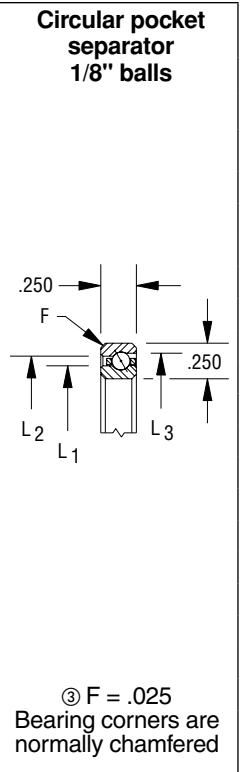

① Capacities listed are not simultaneous. For combined loading see discussion of Bearing Selection and Load Analysis. Dynamic capacities are based upon 1 million revolutions of L10 life. Published capacities do not apply to hybrid series bearings P, X, and Y - contact KAYDON product engineering for values.

② Static capacities are non-brinell limits based on rigid support from the shaft and housing.

③ "F" is the maximum shaft or housing fillet radius the bearing corners will clear.

* Contact KAYDON for lead time and minimum purchase requirement.

Open ENDURAKOTE®-PLATED ENDURA-SLIM® Bearings Type A Angular Contact

NB SERIES										
KAYDON Bearing Number	Dimensions in Inches					Capacities in Pounds ^①				Weight in Pounds
	Bore	Outside Dia.	Land Dia. L ₁	Land Dia. L ₂	C'Bore Dia. L ₃	Radial		Thrust		
						Static ^②	Dyn.	Static ^②	Dyn.	
NB020AR0	2.0000	2.6252	2.231	2.393	2.464	1,090	601	3,150	1,380	.15
NB025AR0	2.5000	3.1252	2.731	2.893	2.964	1,340	675	3,860	1,590	.19
NB030AR0	3.0000	3.6252	3.231	3.393	3.462	1,550	734	4,470	1,750	.22
NB035AR0	3.5000	4.1252	3.731	3.893	3.962	1,790	801	5,180	1,930	.27
NB040AR0	3.9998	4.6253	4.231	4.393	4.460	2,040	865	5,890	2,100	.30
NB042AR0	4.2498	4.8753	4.481	4.643	4.710	2,150	891	6,200	2,170	.31
*NB045AR0	4.4998	5.1253	4.731	4.893	4.960	2,250	917	6,500	2,240	.34
*NB047AR0	4.7498	5.3753	4.981	5.143	5.210	2,390	951	6,910	2,340	.35
*NB050AR0	4.9998	5.6253	5.231	5.393	5.460	2,500	976	7,210	2,410	.37
NB055AR0	5.4998	6.1253	5.731	5.893	5.958	2,740	1,033	7,920	2,560	.40
NB060AR0	5.9998	6.6253	6.231	6.393	6.458	2,990	1,088	8,630	2,710	.44
*NB065AR0	6.4998	7.1253	6.731	6.893	6.958	3,200	1,132	9,240	2,840	.47
*NB070AR0	6.9998	7.6253	7.231	7.393	7.456	3,450	1,184	9,960	2,980	.50
*NB075AR0	7.4998	8.1253	7.731	7.893	7.955	3,700	1,235	10,670	3,120	.54
*NB080AR0	7.9998	8.6253	8.231	8.393	8.453	3,940	1,284	11,380	3,260	.57
NB090AR0	8.9998	9.6253	9.231	9.393	9.451	4,400	1,370	12,700	3,510	.64
*NB100AR0	9.9998	10.6253	10.231	10.393	10.449	4,890	1,461	14,120	3,760	.71
*NB110AR0	10.9998	11.6253	11.231	11.393	11.447	5,350	1,540	15,440	4,000	.78
*NB120AR0	11.9998	12.6253	12.231	12.393	12.445	5,840	1,623	16,860	4,240	.85
*NB140AR0	13.9998	14.6253	14.231	14.393	14.439	6,760	1,767	19,500	4,670	.98
*NB160AR0	15.9998	16.6253	16.231	16.393	16.433	7,710	1,907	22,250	5,100	1.12
*NB180AR0	17.9998	18.6253	18.231	18.393	18.425	8,660	2,038	24,990	5,510	1.26
*NB200AR0	19.9998	20.6253	20.231	20.393	20.416	9,610	2,162	27,730	5,900	1.40

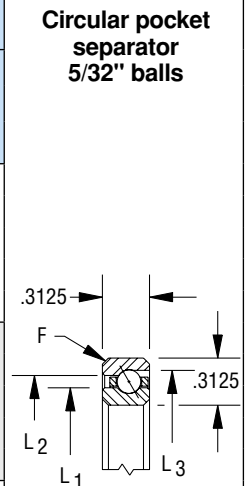

③ F = .040
Bearing corners are normally chamfered

① Capacities listed are not simultaneous. For combined loading see discussion of Bearing Selection and Load Analysis. Dynamic capacities are based upon 1 million revolutions of L10 life. Published capacities do not apply to hybrid series bearings P, X, and Y - contact KAYDON product engineering for values.
 ② Static capacities are non-brinell limits based on rigid support from the shaft and housing.
 ③ "F" is the maximum shaft or housing fillet radius the bearing corners will clear.
 * Contact KAYDON for lead time and minimum purchase requirement.

CONTACT KAYDON AT—
 KAYDON Corporation • Muskegon, Michigan 49443
 Telephone: 231/755-3741 • Fax: 231/759-4102
NEED SERVICE FAST?
 1-800-514-3066
 Website: www.kaydonbearings.com

Open ENDURAKOTE®-PLATED ENDURA-SLIM® Bearings Type A Angular Contact

NC SERIES											Circular pocket separator 3/16" balls
KAYDON Bearing Number	Dimensions in Inches					Capacities in Pounds ^①				Weight in Pounds	
	Bore	Outside Dia.	Land Dia. L ₁	Land Dia. L ₂	C'Bore Dia. L ₃	Radial		Thrust			
						Static ^②	Dyn.	Static ^②	Dyn.		
NC040AR0	3.9998	4.7503	4.277	4.473	4.554	2,550	1,153	7,360	2,770	.44	
*NC042AR0	4.2498	5.0003	4.527	4.723	4.804	2,710	1,194	7,820	2,880	.46	
NC045AR0	4.4998	5.2503	4.777	4.973	5.052	2,860	1,234	8,270	2,990	.49	
NC047AR0	4.7498	5.5003	5.027	5.223	5.302	3,020	1,274	8,720	3,100	.51	
NC050AR0	4.9998	5.7503	5.277	5.473	5.552	3,180	1,313	9,170	3,200	.54	
NC055AR0	5.4998	6.2503	5.777	5.973	6.052	3,440	1,374	9,920	3,370	.58	
NC060AR0	5.9998	6.7503	6.277	6.473	6.550	3,750	1,448	10,820	3,580	.64	
*NC065AR0	6.4998	7.2503	6.777	6.973	7.050	4,060	1,519	11,720	3,770	.68	
NC070AR0	6.9998	7.7503	7.277	7.473	7.550	4,320	1,575	12,470	3,930	.74	
*NC075AR0	7.4998	8.2503	7.777	7.973	8.048	4,630	1,642	13,380	4,120	.78	
NC080AR0	7.9998	8.7503	8.277	8.473	8.548	4,950	1,708	14,280	4,300	.84	
*NC090AR0	8.9998	9.7503	9.277	9.473	9.546	5,520	1,822	15,930	4,630	.98	
*NC100AR0	9.9998	10.7503	10.277	10.473	10.544	6,140	1,942	17,730	4,970	1.04	
*NC110AR0	10.9998	11.7503	11.277	11.473	11.542	6,720	2,047	19,390	5,280	1.14	
*NC120AR0	11.9998	12.7503	12.277	12.473	12.540	7,290	2,147	21,040	5,570	1.23	
*NC140AR0	13.9998	14.7503	14.277	14.473	14.535	8,490	2,347	24,500	6,170	1.43	
*NC160AR0	15.9998	16.7503	16.277	16.473	16.529	9,680	2,533	27,950	6,730	1.63	
*NC180AR0	17.9998	18.7503	18.277	18.473	18.523	10,880	2,707	31,410	7,280	1.83	
*NC200AR0	19.9998	20.7503	20.277	20.473	20.517	12,030	2,863	34,720	7,780	2.03	
*NC250AR0	24.9998	25.7503	25.277	25.473	25.500	14,900	3,233	43,280	9,010	2.52	
*NC300AR0	29.9998	30.7503	30.277	30.473	30.484	17,960	3,561	51,850	10,160	3.02	

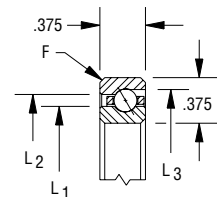

③ F = .040
Bearing corners are normally chamfered

ND SERIES											Circular pocket separator 1/4" balls
KAYDON Bearing Number	Dimensions in Inches					Capacities in Pounds ^①				Weight in Pounds	
	Bore	Outside Dia.	Land Dia. L ₁	Land Dia. L ₂	C'Bore Dia. L ₃	Radial		Thrust			
						Static ^②	Dyn.	Static ^②	Dyn.		
ND040AR0	3.9998	5.0003	4.370	4.630	4.741	3,550	1,819	10,260	4,260	.80	
ND042AR0	4.2498	5.2503	4.620	4.880	4.991	3,750	1,876	10,830	4,420	.84	
ND045AR0	4.4998	5.5003	4.870	5.130	5.241	3,950	1,931	11,400	4,570	.88	
ND047AR0	4.7498	5.7503	5.120	5.380	5.490	4,150	1,986	11,970	4,720	.93	
ND050AR0	4.9998	6.0003	5.370	5.630	5.740	4,340	2,040	12,540	4,870	.98	
ND055AR0	5.4998	6.5003	5.870	6.130	6.238	4,740	2,145	13,680	5,160	1.06	
ND060AR0	5.9998	7.0003	6.370	6.630	6.738	5,130	2,247	14,820	5,440	1.15	
ND065AR0	6.4998	7.5003	6.870	7.130	7.236	5,530	2,346	15,960	5,720	1.24	
ND070AR0	6.9998	8.0003	7.370	7.630	7.736	5,920	2,442	17,100	5,990	1.33	
ND075AR0	7.4998	8.5003	7.870	8.130	8.236	6,320	2,536	18,240	6,250	1.42	
ND080AR0	7.9998	9.0003	8.370	8.630	8.734	6,710	2,627	19,380	6,510	1.52	
ND090AR0	8.9998	10.0003	9.370	9.630	9.732	7,500	2,803	21,660	7,010	1.69	
*ND100AR0	9.9998	11.0003	10.370	10.630	10.732	8,290	2,972	23,940	7,500	1.87	
*ND110AR0	10.9998	12.0003	11.370	11.630	11.730	9,080	3,133	26,220	7,960	2.05	
ND120AR0	11.9998	13.0003	12.370	12.630	12.728	9,870	3,288	28,500	8,420	2.23	
*ND140AR0	13.9998	15.0003	14.370	14.630	14.724	11,450	3,582	33,060	9,290	2.57	
*ND160AR0	15.9998	17.0003	16.370	16.630	16.718	13,030	3,856	37,620	10,130	2.93	
*ND180AR0	17.9998	19.0003	18.370	18.630	18.712	14,610	4,113	42,180	10,930	3.29	
*ND200AR0	19.9998	21.0003	20.370	20.630	20.705	16,190	4,356	46,740	11,710	3.65	
*ND210AR0	20.9998	22.0003	21.370	21.630	21.700	16,981	4,472	49,020	12,086	3.83	
*ND250AR0	24.9998	26.0003	25.370	25.630	25.688	20,140	4,908	58,140	13,540	4.54	
*ND300AR0	29.9998	31.0003	30.370	30.630	30.672	24,090	5,397	69,540	15,260	5.44	

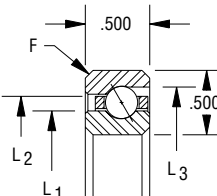

③ F = .060
Bearing corners are normally chamfered

① Capacities listed are not simultaneous. For combined loading see discussion of Bearing Selection and Load Analysis. Dynamic capacities are based upon 1 million revolutions of L10 life. Published capacities do not apply to hybrid series bearings P, X, and Y - contact KAYDON product engineering for values.
 ② Static capacities are non-brinell limits based on rigid support from the shaft and housing.
 ③ "F" is the maximum shaft or housing fillet radius the bearing corners will clear.
 * Contact KAYDON for lead time and minimum purchase requirement.

Open ENDURAKOTE®-PLATED ENDURA-SLIM® Bearings Type A Angular Contact

Section 2-Selection Tables

NF SERIES										
KAYDON Bearing Number	Dimensions in Inches					Capacities in Pounds ^①				Weight in Pounds
	Bore	Outside Dia.	Land Dia. L ₁	Land Dia. L ₂	C'Bore Dia. L ₃	Radial		Thrust		
						Static ^②	Dyn.	Static ^②	Dyn.	
*NF040AR0	3.9998	5.5003	4.555	4.945	5.115	6,350	3,736	18,340	8,420	1.92
*NF042AR0	4.2498	5.7503	4.805	5.195	5.365	6,600	3,805	19,050	8,630	2.04
*NF045AR0	4.4998	6.0003	5.060	5.445	5.615	7,090	3,966	20,460	9,050	2.14
NF047AR0	4.7498	6.2503	5.305	5.695	5.865	7,330	4,034	21,160	9,260	2.26
*NF050AR0	4.9998	6.5003	5.555	5.945	6.115	7,570	4,101	21,870	9,460	2.37
NF055AR0	5.4998	7.0003	6.055	6.445	6.613	8,310	4,319	23,980	10,060	2.59
NF060AR0	5.9998	7.5003	6.555	6.945	7.113	9,040	4,530	26,100	10,650	2.72
NF065AR0	6.4998	8.0003	7.055	7.445	7.613	9,770	4,734	28,220	11,220	2.94
*NF070AR0	6.9998	8.5003	7.555	7.945	8.113	10,510	4,932	30,330	11,770	3.16
NF075AR0	7.4998	9.0003	8.055	8.445	8.610	11,000	5,052	31,740	12,130	3.39
NF080AR0	7.9998	9.5003	8.555	8.945	9.110	11,730	5,242	33,860	12,670	3.61
NF090AR0	8.9998	10.5003	9.555	9.945	10.108	13,190	5,608	38,090	13,700	3.95
NF100AR0	9.9998	11.5003	10.555	10.945	11.106	14,420	5,890	41,620	14,530	4.40
*NF110AR0	10.9998	12.5003	11.555	11.945	12.106	15,880	6,227	45,850	15,500	4.75
NF120AR0	11.9998	13.5003	12.555	12.945	13.104	17,100	6,487	49,380	16,290	5.20
*NF140AR0	13.9998	15.5003	14.555	14.945	15.102	19,790	7,043	57,140	17,950	5.76
*NF160AR0	15.9998	17.5003	16.555	16.945	17.098	22,480	7,563	64,890	19,540	6.78
*NF180AR0	17.9998	19.5003	18.555	18.945	19.096	25,410	8,103	73,360	21,210	7.67
*NF200AR0	19.9998	21.5003	20.555	20.945	21.092	28,100	8,562	81,120	22,680	8.47
*NF250AR0	24.9998	26.5003	25.555	25.945	26.085	34,700	9,585	100,200	26,100	10.50
*NF300AR0	29.9998	31.5003	30.555	30.945	31.075	41,540	10,533	119,900	29,430	12.50
*NF350AR0	34.9998	36.5003	35.555	35.945	36.064	48,380	11,382	139,700	32,580	14.60
*NF400AR0	39.9998	41.5003	40.555	40.945	41.054	55,220	12,147	159,400	35,580	16.60

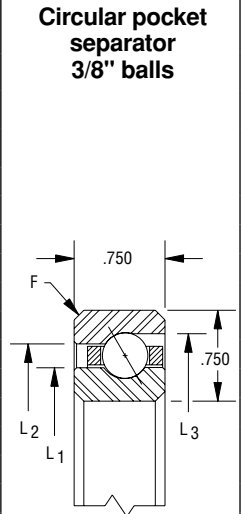

③ F = .080
Bearing corners are normally chamfered

NG SERIES										
KAYDON Bearing Number	Dimensions in Inches					Capacities in Pounds ^①				Weight in Pounds
	Bore	Outside Dia.	Land Dia. L ₁	Land Dia. L ₂	C'Bore Dia. L ₃	Radial		Thrust		
						Static ^②	Dyn.	Static ^②	Dyn.	
*NG040AR0	3.9998	6.0003	4.742	5.258	5.491	9,480	6,281	27,360	13,630	3.61
*NG042AR0	4.2498	6.2503	4.992	5.508	5.741	9,950	6,438	28,730	14,090	3.83
*NG045AR0	4.4998	6.5003	5.242	5.758	5.989	10,430	6,562	30,100	14,530	3.95
*NG047AR0	4.7498	6.7503	5.492	6.008	6.239	10,900	6,745	31,460	14,970	4.17
*NG050AR0	4.9998	7.0003	5.742	6.258	6.489	11,370	6,897	32,830	15,400	4.42
*NG055AR0	5.4998	7.5003	6.242	6.758	6.989	12,320	7,192	35,570	16,240	4.73
NG060AR0	5.9998	8.0003	6.742	7.258	7.489	13,270	7,480	38,300	17,060	5.07
*NG065AR0	6.4998	8.5003	7.242	7.758	7.987	14,220	7,761	41,040	17,870	5.41
*NG070AR0	6.9998	9.0003	7.742	8.258	8.487	15,160	8,035	43,780	18,650	5.87
NG075AR0	7.4998	9.5003	8.242	8.758	8.987	16,110	8,303	46,510	19,420	6.20
NG080AR0	7.9998	10.0003	8.742	9.258	9.485	17,060	8,566	49,250	20,180	6.54
NG090AR0	8.9998	11.0003	9.742	10.258	10.485	18,960	9,073	54,720	21,640	7.22
NG100AR0	9.9998	12.0003	10.742	11.258	11.483	20,850	9,561	60,190	23,060	8.00
*NG110AR0	10.9998	13.0003	11.742	12.258	12.481	22,750	10,027	65,660	24,440	8.68
NG120AR0	11.9998	14.0003	12.742	13.258	13.481	24,640	10,481	71,140	25,780	9.47
NG140AR0	13.9998	16.0003	14.742	15.258	15.478	28,430	11,338	82,080	28,360	10.90
NG160AR0	15.9998	18.0003	16.742	17.258	17.474	32,220	12,142	93,020	30,830	12.40
NG180AR0	17.9998	20.0003	18.742	19.258	19.472	36,020	12,898	104,000	33,200	13.80
NG200AR0	19.9998	22.0003	20.742	21.258	21.468	39,810	13,612	114,900	35,490	15.20
*NG220AR0	21.9998	24.0003	22.742	23.258	23.468	43,598	14,290	125,856	37,712	16.63
*NG250AR0	24.9998	27.0003	25.742	26.258	26.461	49,280	15,239	142,300	40,920	18.80
*NG300AR0	29.9998	32.0003	30.742	31.258	31.451	58,760	16,687	169,600	46,020	22.50
NG350AR0	34.9998	37.0003	35.742	36.258	36.440	68,240	17,982	197,000	50,840	26.20
*NG400AR0	39.9998	42.0003	40.742	41.258	41.430	77,720	19,153	224,400	55,440	29.80

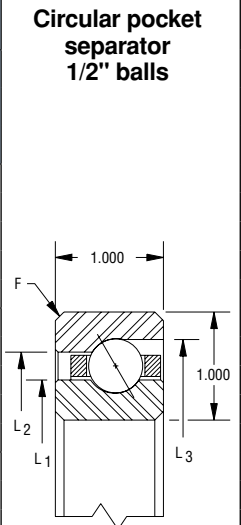

③ F = .080
Bearing corners are normally chamfered

① Capacities listed are not simultaneous. For combined loading see discussion of Bearing Selection and Load Analysis. Dynamic capacities are based upon 1 million revolutions of L10 life. Published capacities do not apply to hybrid series bearings P, X, and Y - contact KAYDON product engineering for values.
 ② Static capacities are non-brinell limits based on rigid support from the shaft and housing.
 ③ "F" is the maximum shaft or housing fillet radius the bearing corners will clear.
 * Contact KAYDON for lead time and minimum purchase requirement.

Open ENDURAKOTE®-PLATED ENDURA-SLIM® Bearing Selections

Type C Radial Contact

A Conrad assembled bearing designed primarily for application of radial load—deep ball grooves also permit application of thrust load in either direction – often used in conjunction with another bearing.

NAA SERIES							
KAYDON Bearing Number	Dimensions in Inches				Radial Capacities in Pounds ^①		Weight in Pounds
	Bore	Outside Dia.	Land Dia. L ₁	Land Dia. L ₂	Static ^②	Dyn.	
NAA10CLO	1.0000	1.3752	1.140	1.235	290	188	.026
NAA15CLO	1.5000	1.8752	1.640	1.735	400	225	.039
NAA17CLO	1.7500	2.1252	1.890	1.985	460	242	.045

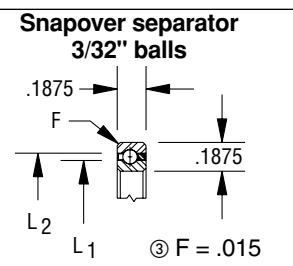

NA SERIES							
KAYDON Bearing Number	Dimensions in Inches				Radial Capacities in Pounds ^①		Weight in Pounds
	Bore	Outside Dia.	Land Dia. L ₁	Land Dia. L ₂	Static ^②	Dyn.	
NA020CP0	2.0000	2.5002	2.186	2.314	680	393	.10
NA025CP0	2.5000	3.0002	2.686	2.814	830	442	.13
NA030CP0	3.0000	3.5002	3.186	3.314	990	487	.15
NA035CP0	3.5000	4.0002	3.686	3.814	1,140	530	.18
NA040CP0	3.9998	4.5003	4.186	4.314	1,290	571	.19
NA042CP0	4.2498	4.7503	4.436	4.564	1,370	591	.20
NA045CP0	4.4998	5.0003	4.686	4.814	1,440	610	.22
NA047CP0	4.7498	5.2503	4.936	5.064	1,520	629	.23
NA050CP0	4.9998	5.5003	5.186	5.314	1,590	648	.24
NA055CP0	5.4998	6.0003	5.686	5.814	1,750	685	.25
NA060CP0	5.9998	6.5003	6.186	6.314	1,900	720	.28
NA065CP0	6.4998	7.0003	6.686	6.814	2,050	754	.30
NA070CP0	6.9998	7.5003	7.186	7.314	2,200	787	.31
NA075CP0	7.4998	8.0003	7.686	7.814	2,350	820	.34
NA080CP0	7.9998	8.5003	8.186	8.314	2,500	851	.38
NA090CP0	8.9998	9.5003	9.186	9.314	2,810	912	.44
NA100CP0	9.9998	10.5003	10.186	10.314	3,110	969	.50
NA110CP0	10.9998	11.5003	11.186	11.314	3,410	1,025	.52
NA120CP0	11.9998	12.5003	12.186	12.314	3,720	1,078	.56

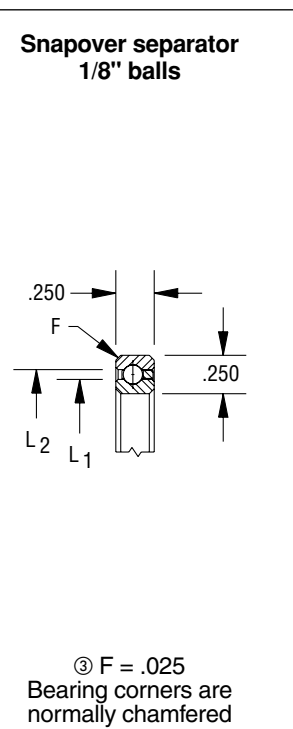

① Capacities listed are not simultaneous. For combined loading see discussion of Bearing Selection and Load Analysis. Dynamic capacities are based upon 1 million revolutions of L10 life. Published capacities do not apply to hybrid series bearings P, X, and Y - contact KAYDON product engineering for values.

② Static capacities are non-brinell limits based on rigid support from the shaft and housing.

③ "F" is the maximum shaft or housing fillet radius the bearing corners will clear.

* Contact KAYDON for lead time and minimum purchase requirement.

Open ENDURAKOTE®-PLATED ENDURA-SLIM® Bearings Type C Radial Contact

NB SERIES							
KAYDON Bearing Number	Dimensions in Inches				Radial Capacities in Pounds ^①		Weight in Pounds
	Bore	Outside Dia.	Land Dia. L ₁	Land Dia. L ₂	Static ^②	Dyn.	
NB020CP0	2.0000	2.6252	2.231	2.393	930	577	.16
NB025CP0	2.5000	3.1252	2.731	2.893	1,140	644	.20
NB030CP0	3.0000	3.6252	3.231	3.393	1,340	707	.24
NB035CP0	3.5000	4.1252	3.731	3.893	1,540	767	.27
NB040CP0	3.9998	4.6253	4.231	4.393	1,750	825	.30
NB042CP0	4.2498	4.8753	4.481	4.643	1,830	846	.31
NB045CP0	4.4998	5.1253	4.731	4.893	1,950	880	.33
*NB047CP0	4.7498	5.3753	4.981	5.143	2,030	901	.34
NB050CP0	4.9998	5.6253	5.231	5.393	2,150	933	.38
*NB055CP0	5.4998	6.1253	5.731	5.893	2,360	984	.41
NB060CP0	5.9998	6.6253	6.231	6.393	2,560	1,034	.44
NB065CP0	6.4998	7.1253	6.731	6.893	2,760	1,082	.47
*NB070CP0	6.9998	7.6253	7.231	7.393	2,970	1,129	.50
*NB075CP0	7.4998	8.1253	7.731	7.893	3,170	1,175	.53
NB080CP0	7.9998	8.6253	8.231	8.393	3,370	1,219	.57
*NB090CP0	8.9998	9.6253	9.231	9.393	3,780	1,304	.66
*NB100CP0	9.9998	10.6253	10.231	10.393	4,190	1,386	.73
*NB110CP0	10.9998	11.6253	11.231	11.393	4,590	1,464	.75
*NB120CP0	11.9998	12.6253	12.231	12.393	5,000	1,539	.83
*NB140CP0	13.9998	14.6253	14.231	14.393	5,810	1,680	1.05
*NB160CP0	15.9998	16.6253	16.231	16.393	6,620	1,812	1.20
*NB180CP0	17.9998	18.6253	18.231	18.393	7,440	1,936	1.35
*NB200CP0	19.9998	20.6253	20.231	20.393	8,250	2,053	1.50

Snapover separator
5/32" balls

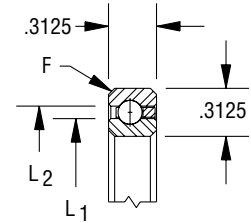

③ F = .040
Bearing corners are normally chamfered

- ① Capacities listed are not simultaneous. For combined loading see discussion of Bearing Selection and Load Analysis. Dynamic capacities are based upon 1 million revolutions of L10 life. Published capacities do not apply to hybrid series bearings P, X, and Y - contact KAYDON product engineering for values.
- ② Static capacities are non-brinell limits based on rigid support from the shaft and housing.
- ③ "F" is the maximum shaft or housing fillet radius the bearing corners will clear.
- * Contact KAYDON for lead time and minimum purchase requirement.

CONTACT KAYDON AT—
 KAYDON Corporation • Muskegon, Michigan 49443
 Telephone: 231/755-3741 • Fax: 231/759-4102

NEED SERVICE FAST?
 1-800-514-3066
 Website: www.kaydonbearings.com

Open ENDURAKOTE®-PLATED ENDURA-SLIM® Bearings Type C Radial Contact

NC SERIES							
KAYDON Bearing Number	Dimensions in Inches				Radial Capacities in Pounds ^①		Weight in Pounds
	Bore	Outside Dia.	Land Dia. L ₁	Land Dia. L ₂	Static ^②	Dyn.	
NC040CP0	3.9998	4.7503	4.277	4.473	2,100	1,073	.45
NC042CP0	4.2498	5.0003	4.527	4.723	2,220	1,108	.47
NC045CP0	4.4998	5.2503	4.777	4.973	2,340	1,143	.48
NC047CP0	4.7498	5.5003	5.027	5.223	2,460	1,176	.50
NC050CP0	4.9998	5.7503	5.277	5.473	2,590	1,209	.58
NC055CP0	5.4998	6.2503	5.777	5.973	2,830	1,274	.59
NC060CP0	5.9998	6.7503	6.277	6.473	3,070	1,337	.63
NC065CP0	6.4998	7.2503	6.777	6.973	3,310	1,397	.68
NC070CP0	6.9998	7.7503	7.277	7.473	3,550	1,457	.73
NC075CP0	7.4998	8.2503	7.777	7.973	3,790	1,514	.78
NC080CP0	7.9998	8.7503	8.277	8.473	4,030	1,570	.84
NC090CP0	8.9998	9.7503	9.277	9.473	4,510	1,678	.94
NC100CP0	9.9998	10.7503	10.277	10.473	4,990	1,781	1.06
*NC110CP0	10.9998	11.7503	11.277	11.473	5,470	1,879	1.16
NC120CP0	11.9998	12.7503	12.277	12.473	5,950	1,974	1.25
NC140CP0	13.9998	14.7503	14.277	14.473	6,910	2,154	1.52
NC160CP0	15.9998	16.7503	16.277	16.473	7,880	2,321	1.73
*NC180CP0	17.9998	18.7503	18.277	18.473	8,840	2,478	1.94
*NC200CP0	19.9998	20.7503	20.277	20.473	9,800	2,626	2.16
*NC250CP0	24.9998	25.7503	25.277	25.473	12,200	2,962	2.69
*NC300CP0	29.9998	30.7503	30.277	30.473	14,610	3,260	3.21

Snapover separator
3/16" balls

③ F = .040
Bearing corners are normally chamfered

ND SERIES							
KAYDON Bearing Number	Dimensions in Inches				Radial Capacities in Pounds ^①		Weight in Pounds
	Bore	Outside Dia.	Land Dia. L ₁	Land Dia. L ₂	Static ^②	Dyn.	
ND040CP0	3.9998	5.0003	4.370	4.630	3,080	1,755	.78
ND042CP0	4.2498	5.2503	4.620	4.880	3,190	1,787	.83
ND045CP0	4.4998	5.5003	4.870	5.130	3,420	1,861	.88
ND047CP0	4.7498	5.7503	5.120	5.380	3,530	1,892	.94
ND050CP0	4.9998	6.0003	5.370	5.630	3,760	1,964	1.00
ND055CP0	5.4998	6.5003	5.870	6.130	4,100	2,063	1.06
ND060CP0	5.9998	7.0003	6.370	6.630	4,450	2,160	1.16
ND065CP0	6.4998	7.5003	6.870	7.130	4,790	2,254	1.22
ND070CP0	6.9998	8.0003	7.370	7.630	5,130	2,345	1.31
ND075CP0	7.4998	8.5003	7.870	8.130	5,470	2,434	1.41
ND080CP0	7.9998	9.0003	8.370	8.630	5,810	2,520	1.53
ND090CP0	8.9998	10.0003	9.370	9.630	6,500	2,688	1.72
ND100CP0	9.9998	11.0003	10.370	10.630	7,180	2,847	1.88
ND110CP0	10.9998	12.0003	11.370	11.630	7,870	3,000	2.06
ND120CP0	11.9998	13.0003	12.370	12.630	8,550	3,148	2.25
*ND140CP0	13.9998	15.0003	14.370	14.630	9,920	3,427	2.73
*ND160CP0	15.9998	17.0003	16.370	16.630	11,290	3,688	3.10
*ND180CP0	17.9998	19.0003	18.370	18.630	12,650	3,933	3.48
*ND200CP0	19.9998	21.0003	20.370	20.630	14,020	4,164	3.85
*ND210CP0	20.9998	22.0003	21.370	21.630	14,706	4,274	4.04
*ND250CP0	24.9998	26.0003	25.370	25.630	17,440	4,689	4.79
*ND300CP0	29.9998	31.0003	30.370	30.360	20,860	5,153	5.73

Snapover separator
1/4" balls

③ F = .060
Bearing corners are normally chamfered

① Capacities listed are not simultaneous. For combined loading see discussion of Bearing Selection and Load Analysis. Dynamic capacities are based upon 1 million revolutions of L10 life. Published capacities do not apply to hybrid series bearings P, X, and Y - contact KAYDON product engineering for values.
 ② Static capacities are non-brinell limits based on rigid support from the shaft and housing.
 ③ "F" is the maximum shaft or housing fillet radius the bearing corners will clear.
 * Contact KAYDON for lead time and minimum purchase requirement.

Open ENDURAKOTE®-PLATED ENDURA-SLIM® Bearings Type C Radial Contact

Section 2-Selection Tables

NF SERIES							
KAYDON Bearing Number	Dimensions in Inches				Radial Capacities in Pounds ^①		Weight in Pounds
	Bore	Outside Dia.	Land Dia. L ₁	Land Dia. L ₂	Static ^②	Dyn.	
NF040CP0	3.9998	5.5003	4.555	4.945	5,360	3,559	1.9
NF042CP0	4.2498	5.7503	4.805	5.195	5,640	3,655	2.0
*NF045CP0	4.4998	6.0003	5.055	5.445	5,930	3,750	2.1
NF047CP0	4.7498	6.2503	5.305	5.695	6,210	3,843	2.2
NF050CP0	4.9998	6.5003	5.555	5.945	6,490	3,936	2.3
NF055CP0	5.4998	7.0003	6.055	6.445	7,050	4,116	2.5
NF060CP0	5.9998	7.5003	6.555	6.945	7,620	4,291	2.7
NF065CP0	6.4998	8.0003	7.055	7.445	8,180	4,461	2.9
*NF070CP0	6.9998	8.5003	7.555	7.945	8,750	4,628	3.2
NF075CP0	7.4998	9.0003	8.055	8.445	9,310	4,791	3.4
NF080CP0	7.9998	9.5003	8.555	8.945	9,880	4,949	3.5
NF090CP0	8.9998	10.5003	9.555	9.945	11,000	5,256	3.9
NF100CP0	9.9998	11.5003	10.555	10.945	12,130	5,550	4.3
NF110CP0	10.9998	12.5003	11.555	11.945	13,260	5,833	4.8
NF120CP0	11.9998	13.5003	12.555	12.945	14,390	6,105	5.2
*NF140CP0	13.9998	15.5003	14.555	14.945	16,650	6,620	6.0
*NF160CP0	15.9998	17.5003	16.555	16.945	18,900	7,104	7.1
*NF180CP0	17.9998	19.5003	18.555	18.945	21,160	7,557	7.9
*NF200CP0	19.9998	21.5003	20.555	20.945	23,420	7,986	8.9
*NF250CP0	24.9998	26.5003	25.555	25.945	29,060	8,963	10.9
*NF300CP0	29.9998	31.5003	30.555	30.945	34,700	9,828	13.0
*NF350CP0	34.9998	36.5003	35.555	35.945	40,350	10,603	15.1
*NF400CP0	39.9998	41.5003	40.555	40.945	45,990	11,302	17.2

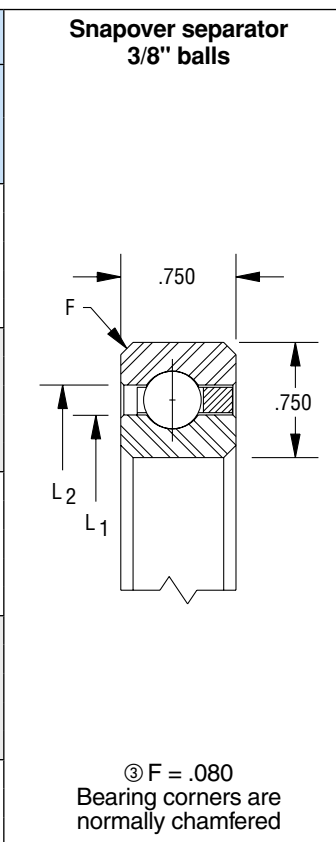

NG SERIES							
KAYDON Bearing Number	Dimensions in Inches				Radial Capacities in Pounds ^①		Weight in Pounds
	Bore	Outside Dia.	Land Dia. L ₁	Land Dia. L ₂	Static ^②	Dyn.	
*NG040CP0	3.9998	6.0003	4.742	5.258	8,210	6,115	3.6
*NG042CP0	4.2498	6.2503	4.992	5.508	8,210	6,061	3.8
*NG045CP0	4.4998	6.5003	5.242	5.758	8,760	6,277	4.0
*NG047CP0	4.7498	6.7503	5.492	6.008	9,300	6,487	4.1
NG050CP0	4.9998	7.0003	5.742	6.258	9,850	6,691	4.3
*NG055CP0	5.4998	7.5003	6.242	6.758	10,400	6,850	4.7
*NG060CP0	5.9998	8.0003	6.742	7.258	11,490	7,241	5.1
NG065CP0	6.4998	8.5003	7.242	7.758	12,040	7,393	5.4
*NG070CP0	6.9998	9.0003	7.742	8.258	13,130	7,764	5.8
NG075CP0	7.4998	9.5003	8.242	8.758	13,680	7,911	6.1
NG080CP0	7.9998	10.0003	8.742	9.258	14,770	8,265	6.5
NG090CP0	8.9998	11.0003	9.742	10.258	16,420	8,743	7.2
NG100CP0	9.9998	12.0003	10.742	11.258	18,060	9,204	7.9
NG110CP0	10.9998	13.0003	11.742	12.258	19,700	9,648	8.6
NG120CP0	11.9998	14.0003	12.742	13.258	21,340	10,074	9.3
NG140CP0	13.9998	16.0003	14.742	15.258	24,620	10,886	10.8
NG160CP0	15.9998	18.0003	16.742	17.258	27,910	11,648	12.3
NG180CP0	17.9998	20.0003	18.742	19.258	31,190	12,367	13.7
NG200CP0	19.9998	22.0003	20.742	21.258	34,470	13,044	15.8
*NG220CP0	21.9998	24.0003	22.742	23.258	37,757	13,685	16.8
*NG250CP0	24.9998	27.0003	25.742	26.258	42,680	14,591	19.5
*NG300CP0	29.9998	32.0003	30.742	31.258	50,890	15,963	23.3
*NG350CP0	34.9998	37.0003	35.742	36.258	59,100	17,195	27.1
*NG400CP0	39.9998	42.0003	40.742	41.258	67,310	18,307	30.8

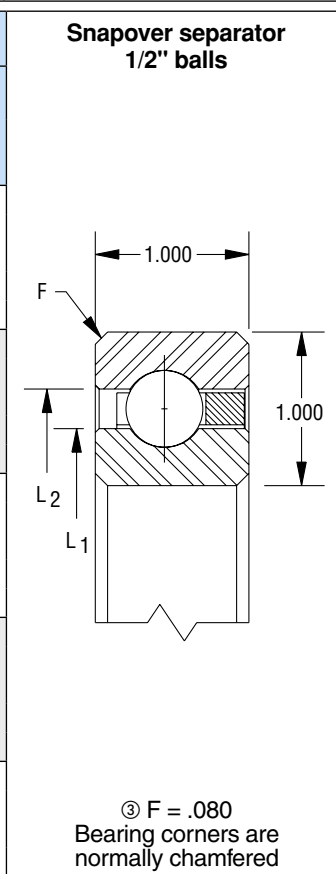

① Capacities listed are not simultaneous. For combined loading see discussion of Bearing Selection and Load Analysis. Dynamic capacities are based upon 1 million revolutions of L10 life. Published capacities do not apply to hybrid series bearings P, X, and Y - contact KAYDON product engineering for values.
 ② Static capacities are non-brinell limits based on rigid support from the shaft and housing.
 ③ "F" is the maximum shaft or housing fillet radius the bearing corners will clear.
 * Contact KAYDON for lead time and minimum purchase requirement.

Open ENDURAKOTE®-PLATED ENDURA-SLIM® Bearing Selections

Type X Four-Point Contact

A Conrad-assembled bearing designed for applications involving multiple loads. Unique internal geometry permits application of radial load, thrust load in either direction, and moment load, individually or in any combination. A single four-point contact bearing may replace two bearings in many applications.

NAA SERIES											
KAYDON Bearing Number	Dimensions in Inches				Capacities ^①						Weight in Pounds
	Bore	Outside Dia.	Land Dia. L ₁	Land Dia. L ₂	Radial (lbs)		Thrust (lbs)		Moment (in-lbs)		
					Static ^②	Dyn.	Static ^②	Dyn.	Static ^②	Dyn.	
NAA10XLO	1.0000	1.3752	1.140	1.235	290	247	730	370	170	110	.026
NAA15XLO	1.5000	1.8752	1.640	1.735	400	296	1,000	460	340	187	.039
NAA17XLO	1.7500	2.1252	1.890	1.985	460	319	1,140	500	440	232	.045

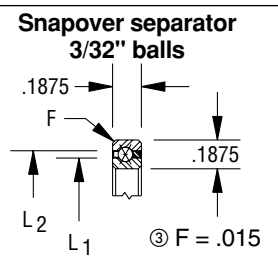

NA SERIES											
KAYDON Bearing Number	Dimensions in Inches				Capacities ^①						Weight in Pounds
	Bore	Outside Dia.	Land Dia. L ₁	Land Dia. L ₂	Radial (lbs)		Thrust (lbs)		Moment (in-lbs)		
					Static ^②	Dyn.	Static ^②	Dyn.	Static ^②	Dyn.	
NA020XP0	2.0000	2.5002	2.186	2.314	680	514	1,710	790	770	434	.10
NA025XP0	2.5000	3.0002	2.686	2.814	830	583	2,090	910	1,150	601	.13
NA030XP0	3.0000	3.5002	3.186	3.314	990	643	2,470	1,010	1,600	785	.15
NA035XP0	3.5000	4.0002	3.686	3.814	1,140	701	2,850	1,110	2,130	986	.18
NA040XP0	3.9998	4.5003	4.186	4.314	1,290	756	3,220	1,210	2,740	1,205	.19
NA042XP0	4.2498	4.7503	4.436	4.564	1,370	783	3,410	1,260	3,070	1,321	.20
NA045XP0	4.4998	5.0003	4.686	4.814	1,440	809	3,600	1,310	3,420	1,441	.22
NA047XP0	4.7498	5.2503	4.936	5.064	1,520	834	3,790	1,350	3,790	1,565	.23
NA050XP0	4.9998	5.5003	5.186	5.314	1,590	859	3,980	1,400	4,180	1,693	.24
NA055XP0	5.4998	6.0003	5.686	5.814	1,750	908	4,360	1,480	5,020	1,959	.25
NA060XP0	5.9998	6.5003	6.186	6.314	1,900	955	4,740	1,570	5,930	2,240	.28
NA065XP0	6.4998	7.0003	6.686	6.814	2,050	1,001	5,120	1,650	6,910	2,535	.30
NA070XP0	6.9998	7.5003	7.186	7.314	2,200	1,046	5,500	1,730	7,980	2,844	.31
NA075XP0	7.4998	8.0003	7.686	7.814	2,350	1,089	5,880	1,810	9,120	3,165	.34
NA080XP0	7.9998	8.5003	8.186	8.314	2,500	1,131	6,260	1,890	10,330	3,499	.38
NA090XP0	8.9998	9.5003	9.186	9.314	2,810	1,212	7,020	2,040	12,990	4,204	.44
NA100XP0	9.9998	10.5003	10.186	10.314	3,110	1,289	7,780	2,180	15,940	4,956	.50
*NA110XP0	10.9998	11.5003	11.186	11.314	3,410	1,362	8,540	2,320	19,210	5,750	.52
NA120XP0	11.9998	12.5003	12.186	12.314	3,720	1,433	9,300	2,450	22,770	6,587	.56

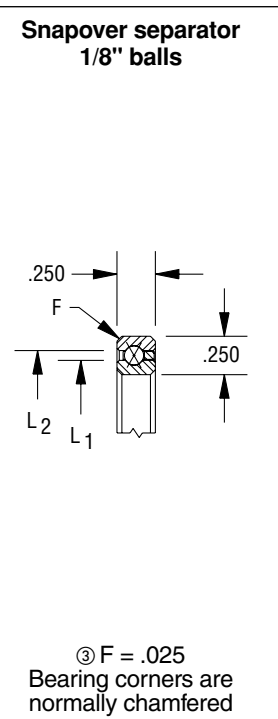

① Capacities listed are not simultaneous. For combined loading see discussion of Bearing Selection and Load Analysis. Dynamic capacities are based upon 1 million revolutions of L10 life. Published capacities do not apply to hybrid series bearings P, X, and Y - contact KAYDON product engineering for values.
 ② Static capacities are non-brinell limits based on rigid support from the shaft and housing.
 ③ "F" is the maximum shaft or housing fillet radius the bearing corners will clear.
 * Contact KAYDON for lead time and minimum purchase requirement.

Open ENDURAKOTE®-PLATED ENDURA-SLIM® Bearings Type X Four-Point Contact

NB SERIES												
KAYDON Bearing Number	Dimensions in Inches				Capacities ^①						Weight in Pounds	
	Bore	Outside Dia.	Land Dia. L ₁	Land Dia. L ₂	Radial (lbs)		Thrust (lbs)		Moment (in-lbs)			
					Static ^②	Dyn.	Static ^②	Dyn.	Static ^②	Dyn.		
NB020XP0	2.0000	2.6252	2.231	2.393	930	758	2,340	1,130	1,080	658	.16	
NB025XP0	2.5000	3.1252	2.731	2.893	1,140	848	2,840	1,290	1,600	895	.19	
NB030XP0	3.0000	3.6252	3.231	3.393	1,340	933	3,350	1,440	2,220	1,159	.24	
NB035XP0	3.5000	4.1252	3.731	3.893	1,540	1,014	3,860	1,590	2,940	1,450	.27	
NB040XP0	3.9998	4.6253	4.231	4.393	1,750	1,091	4,370	1,720	3,770	1,764	.30	
NB042XP0	4.2498	4.8753	4.481	4.643	1,830	1,120	4,570	1,780	4,170	1,917	.31	
NB045XP0	4.4998	5.1253	4.731	4.893	1,950	1,165	4,880	1,850	4,690	2,103	.33	
*NB047XP0	4.7498	5.3753	4.981	5.143	2,030	1,193	5,080	1,900	5,140	2,265	.34	
NB050XP0	4.9998	5.6253	5.231	5.393	2,150	1,236	5,380	1,980	5,720	2,463	.38	
NB055XP0	5.4998	6.1253	5.731	5.893	2,360	1,304	5,890	2,100	6,850	2,844	.41	
NB060XP0	5.9998	6.6253	6.231	6.393	2,560	1,371	6,400	2,220	8,080	3,247	.44	
NB065XP0	6.4998	7.1253	6.731	6.893	2,760	1,435	6,910	2,340	9,410	3,668	.47	
*NB070XP0	6.9998	7.6253	7.231	7.393	2,970	1,498	7,420	2,450	10,850	4,109	.50	
*NB075XP0	7.4998	8.1253	7.731	7.893	3,170	1,559	7,920	2,560	12,380	4,568	.53	
NB080XP0	7.9998	8.6253	8.231	8.393	3,370	1,618	8,430	2,670	14,020	5,045	.57	
NB090XP0	8.9998	9.6253	9.231	9.393	3,780	1,732	9,450	2,880	17,600	6,050	.66	
*NB100XP0	9.9998	10.6253	10.231	10.393	4,190	1,841	10,460	3,080	21,580	7,121	.73	
*NB110XP0	10.9998	11.6253	11.231	11.393	4,590	1,945	11,480	3,280	25,970	8,254	.75	
*NB120XP0	11.9998	12.6253	12.231	12.393	5,000	2,045	12,500	3,470	30,770	9,446	.83	
*NB140XP0	13.9998	14.6253	14.231	14.393	5,810	2,234	14,530	3,840	41,580	11,994	1.05	
NB160XP0	15.9998	16.6253	16.231	16.393	6,620	2,410	16,560	4,190	54,020	14,750	1.20	
*NB180XP0	17.9998	18.6253	18.231	18.393	7,440	2,576	18,590	4,520	68,090	17,694	1.35	
*NB200XP0	19.9998	20.6253	20.231	20.393	8,250	2,731	20,620	4,850	83,780	20,813	1.50	

Snapover separator
5/32" balls

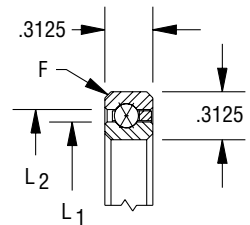

③ F = .040
Bearing corners are normally chamfered

① Capacities listed are not simultaneous. For combined loading see discussion of Bearing Selection and Load Analysis. Dynamic capacities are based upon 1 million revolutions of L10 life. Published capacities do not apply to hybrid series bearings P, X, and Y - contact KAYDON product engineering for values.
 ② Static capacities are non-brinell limits based on rigid support from the shaft and housing.
 ③ "F" is the maximum shaft or housing fillet radius the bearing corners will clear.
 * Contact KAYDON for lead time and minimum purchase requirement.

CONTACT KAYDON AT—
 KAYDON Corporation • Muskegon, Michigan 49443
 Telephone: 231/755-3741 • Fax: 231/759-4102
NEED SERVICE FAST?
 1-800-514-3066
 Website: www.kaydonbearings.com

Open ENDURAKOTE®-PLATED ENDURA-SLIM® Bearings Type X Four-Point Contact

NC SERIES											
KAYDON Bearing Number	Dimensions in Inches				Capacities ^①						Weight in Pounds
	Bore	Outside Dia.	Land Dia. L ₁	Land Dia. L ₂	Radial (lbs)		Thrust (lbs)		Moment (in-lbs)		
					Static ^②	Dyn.	Static ^②	Dyn.	Static ^②	Dyn.	
NC040XP0	3.9998	4.7503	4.277	4.473	2,100	1,417	5,260	2,210	4,600	2,326	.45
*NC042XP0	4.2498	5.0003	4.527	4.723	2,220	1,464	5,560	2,290	5,140	2,541	.47
NC045XP0	4.4998	5.2503	4.777	4.973	2,340	1,510	5,860	2,380	5,710	2,762	.48
NC047XP0	4.7498	5.5003	5.027	5.223	2,460	1,556	6,160	2,460	6,320	2,991	.50
NC050XP0	4.9998	5.7503	5.277	5.473	2,590	1,600	6,460	2,540	6,950	3,226	.58
NC055XP0	5.4998	6.2503	5.777	5.973	2,830	1,687	7,060	2,690	8,300	3,717	.59
NC060XP0	5.9998	6.7503	6.277	6.473	3,070	1,770	7,660	2,840	9,770	4,234	.63
NC065XP0	6.4998	7.2503	6.777	6.973	3,310	1,851	8,270	2,990	11,370	4,775	.68
NC070XP0	6.9998	7.7503	7.277	7.473	3,550	1,931	8,870	3,130	13,080	5,341	.73
*NC075XP0	7.4998	8.2503	7.777	7.973	3,790	2,007	9,470	3,270	14,910	5,930	.78
NC080XP0	7.9998	8.7503	8.277	8.473	4,030	2,082	10,070	3,410	16,870	6,542	.84
NC090XP0	8.9998	9.7503	9.277	9.473	4,510	2,226	11,270	3,670	21,130	7,830	.94
NC100XP0	9.9998	10.7503	10.277	10.473	4,990	2,364	12,470	3,930	25,880	9,201	1.06
NC110XP0	10.9998	11.7503	11.277	11.473	5,470	2,496	13,680	4,180	31,110	10,651	1.16
NC120XP0	11.9998	12.7503	12.277	12.473	5,950	2,622	14,880	4,420	36,830	12,174	1.25
NC140XP0	13.9998	14.7503	14.277	14.473	6,910	2,862	17,280	4,890	49,690	15,434	1.52
NC160XP0	15.9998	16.7503	16.277	16.473	7,880	3,086	19,690	5,330	64,480	18,955	1.73
*NC180XP0	17.9998	18.7503	18.277	18.473	8,840	3,295	22,090	5,760	81,190	22,712	1.94
*NC200XP0	19.9998	20.7503	20.277	20.473	9,800	3,492	24,500	6,170	99,830	26,695	2.16
*NC250XP0	24.9998	25.7503	25.277	25.473	12,200	3,941	30,510	7,140	154,800	37,518	2.69
*NC300XP0	29.9998	30.7503	30.277	30.473	14,610	4,338	36,520	8,050	221,900	49,436	3.21

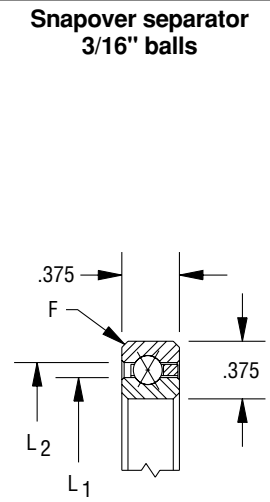

③ F = .040
Bearing corners are normally chamfered

ND SERIES											
KAYDON Bearing Number	Dimensions in Inches				Capacities ^①						Weight in Pounds
	Bore	Outside Dia.	Land Dia. L ₁	Land Dia. L ₂	Radial (lbs)		Thrust (lbs)		Moment (in-lbs)		
					Static ^②	Dyn.	Static ^②	Dyn.	Static ^②	Dyn.	
ND040XP0	3.9998	5.0003	4.370	4.630	3,080	2,311	7,700	3,520	6,930	3,901	.78
ND042XP0	4.2498	5.2503	4.620	4.880	3,190	2,355	7,980	3,600	7,580	4,196	.83
ND045XP0	4.4998	5.5003	4.870	5.130	3,420	2,454	8,550	3,770	8,550	4,602	.88
ND047XP0	4.7498	5.7503	5.120	5.380	3,530	2,496	8,840	3,860	9,280	4,916	.94
ND050XP0	4.9998	6.0003	5.370	5.630	3,760	2,592	9,410	4,020	10,350	5,348	1.00
ND055XP0	5.4998	6.5003	5.870	6.130	4,100	2,725	10,260	4,260	12,310	6,134	1.06
ND060XP0	5.9998	7.0003	6.370	6.630	4,450	2,855	11,120	4,490	14,450	6,961	1.16
ND065XP0	6.4998	7.5003	6.870	7.130	4,790	2,980	11,970	4,720	16,760	7,826	1.22
ND070XP0	6.9998	8.0003	7.370	7.630	5,130	3,103	12,830	4,940	19,240	8,730	1.31
ND075XP0	7.4998	8.5003	7.870	8.130	5,470	3,222	13,680	5,160	21,890	9,669	1.41
ND080XP0	7.9998	9.0003	8.370	8.630	5,810	3,338	14,540	5,370	24,710	10,643	1.53
ND090XP0	8.9998	10.0003	9.370	9.630	6,500	3,561	16,250	5,790	30,870	12,693	1.72
ND100XP0	9.9998	11.0003	10.370	10.630	7,180	3,776	17,960	6,190	37,710	14,872	1.88
ND110XP0	10.9998	12.0003	11.370	11.630	7,870	3,981	19,670	6,570	45,230	17,173	2.06
ND120XP0	11.9998	13.0003	12.370	12.630	8,550	4,178	21,380	6,950	53,440	19,590	2.25
ND140XP0	13.9998	15.0003	14.370	14.630	9,920	4,551	24,800	7,670	71,910	24,755	2.73
*ND160XP0	15.9998	17.0003	16.370	16.630	11,290	4,899	28,220	8,360	93,110	30,325	3.10
ND180XP0	17.9998	19.0003	18.370	18.630	12,650	5,226	31,640	9,030	117,000	36,268	3.48
ND200XP0	19.9998	21.0003	20.370	20.630	14,020	5,534	35,060	9,670	143,700	42,561	3.85
*ND210XP0	20.9998	22.0003	21.370	21.630	14,710	5,682	36,770	9,980	158,100	45,826	4.04
*ND250XP0	24.9998	26.0003	25.370	25.630	17,440	6,235	43,610	11,180	222,400	59,649	4.79
*ND300XP0	29.9998	31.0003	30.370	30.630	20,860	6,856	52,160	12,600	318,100	78,447	5.73

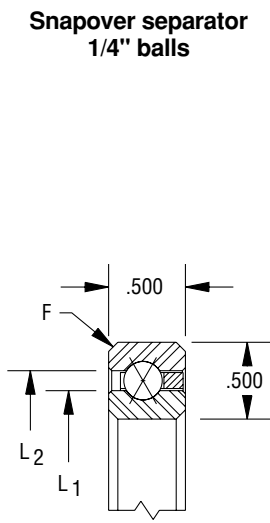

③ F = .060
Bearing corners are normally chamfered

① Capacities listed are not simultaneous. For combined loading see discussion of Bearing Selection and Load Analysis. Dynamic capacities are based upon 1 million revolutions of L10 life. Published capacities do not apply to hybrid series bearings P, X, and Y - contact KAYDON product engineering for values.
 ② Static capacities are non-brinell limits based on rigid support from the shaft and housing.
 ③ "F" is the maximum shaft or housing fillet radius the bearing corners will clear.
 * Contact KAYDON for lead time and minimum purchase requirement.

Open ENDURAKOTE®-PLATED ENDURA-SLIM® Bearings Type X Four-Point Contact

NF SERIES											
KAYDON Bearing Number	Dimensions in Inches				Capacities ^①						Weight in Pounds
	Bore	Outside Dia.	Land Dia. L ₁	Land Dia. L ₂	Radial (lbs)		Thrust (lbs)		Moment (in-lbs)		
					Static ^②	Dyn.	Static ^②	Dyn.	Static ^②	Dyn.	
NF040XP0	3.9998	5.5003	4.555	4.945	5,360	4,665	13,400	6,830	12,730	8,312	1.9
NF042XP0	4.2498	5.7503	4.805	5.195	5,640	4,795	14,110	7,070	14,110	8,993	2.0
NF045XP0	4.4998	6.0003	5.055	5.445	5,930	4,923	14,810	7,300	15,550	9,695	2.1
NF047XP0	4.7498	6.2503	5.305	5.695	6,210	5,048	15,520	7,530	17,070	10,416	2.2
NF050XP0	4.9998	6.5003	5.555	5.945	6,490	5,172	16,220	7,760	18,660	11,157	2.3
NF055XP0	5.4998	7.0003	6.055	6.445	7,050	5,415	17,630	8,200	22,040	12,696	2.5
NF060XP0	5.9998	7.5003	6.555	6.945	7,620	5,651	19,050	8,630	25,710	14,311	2.7
NF065XP0	6.4998	8.0003	7.055	7.445	8,180	5,880	20,460	9,050	29,660	15,993	2.9
NF070XP0	6.9998	8.5003	7.555	7.945	8,750	6,103	21,870	9,460	33,890	17,744	3.2
NF075XP0	7.4998	9.0003	8.055	8.445	9,310	6,323	23,280	9,870	38,410	19,568	3.4
NF080XP0	7.9998	9.5003	8.555	8.945	9,880	6,535	24,690	10,260	43,200	21,453	3.5
NF090XP0	8.9998	10.5003	9.555	9.945	11,000	6,947	27,510	11,030	53,640	25,410	3.9
NF100XP0	9.9998	11.5003	10.555	10.945	12,130	7,342	30,330	11,770	65,210	29,608	4.3
NF110XP0	10.9998	12.5003	11.555	11.945	13,260	7,721	33,150	12,490	77,910	34,032	4.8
NF120XP0	11.9998	13.5003	12.555	12.945	14,390	8,084	35,970	13,190	91,730	38,666	5.2
NF140XP0	13.9998	15.5003	14.555	14.945	16,650	8,775	41,620	14,530	122,800	48,556	6.0
*NF160XP0	15.9998	17.5003	16.555	16.945	18,900	9,421	47,260	15,820	158,300	59,200	7.1
*NF180XP0	17.9998	19.5003	18.555	18.945	21,160	10,028	52,900	17,060	198,400	70,537	7.9
*NF200XP0	19.9998	21.5003	20.555	20.945	23,420	10,602	58,550	18,250	243,000	82,528	8.9
*NF250XP0	24.9998	26.5003	25.555	25.945	29,060	11,909	72,650	21,070	374,200	115,037	10.9
*NF300XP0	29.9998	31.5003	30.555	30.945	34,700	13,065	86,760	23,720	533,600	150,708	13.0
*NF350XP0	34.9998	36.5003	35.555	35.945	40,350	14,100	100,900	26,220	721,200	189,106	15.1
*NF400XP0	39.9998	41.5003	40.555	40.945	45,990	15,034	115,000	28,620	937,100	229,832	17.2

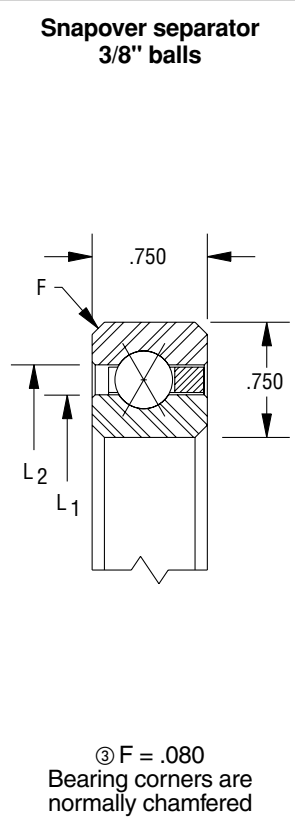

NG SERIES											
KAYDON Bearing Number	Dimensions in Inches				Capacities ^①						Weight in Pounds
	Bore	Outside Dia.	Land Dia. L ₁	Land Dia. L ₂	Radial (lbs)		Thrust (lbs)		Moment (in-lbs)		
					Static ^②	Dyn.	Static ^②	Dyn.	Static ^②	Dyn.	
*NG040XP0	3.9998	6.0003	4.742	5.258	8,210	7,979	20,520	11,260	20,520	14,966	3.6
*NG042XP0	4.2498	6.2503	4.992	5.508	8,210	7,917	20,520	11,260	21,550	15,592	3.8
*NG045XP0	4.4998	6.5003	5.242	5.758	8,760	8,205	21,890	11,750	24,080	16,930	4.0
*NG047XP0	4.7498	6.7503	5.492	6.008	9,300	8,487	23,260	12,230	26,740	18,306	4.1
NG050XP0	4.9998	7.0003	5.742	6.258	9,850	8,762	24,620	12,710	29,550	19,721	4.3
*NG055XP0	5.4998	7.5003	6.242	6.758	10,400	8,979	25,990	13,180	33,790	21,896	4.7
NG060XP0	5.9998	8.0003	6.742	7.258	11,490	9,503	28,730	14,090	40,220	24,956	5.1
*NG065XP0	6.4998	8.5003	7.242	7.758	12,040	9,713	30,100	14,530	45,140	27,327	5.4
*NG070XP0	6.9998	9.0003	7.742	8.258	13,130	10,208	32,830	15,400	52,530	30,636	5.8
NG075XP0	7.4998	9.5003	8.242	8.758	13,680	10,410	34,200	15,820	58,140	33,196	6.1
NG080XP0	7.9998	10.0003	8.742	9.258	14,770	10,882	36,940	16,650	66,480	36,743	6.5
NG090XP0	8.9998	11.0003	9.742	10.258	16,420	11,526	41,040	17,870	82,080	43,240	7.2
NG100XP0	9.9998	12.0003	10.742	11.258	18,060	12,147	45,140	19,040	99,320	50,124	7.9
NG110XP0	10.9998	13.0003	11.742	12.258	19,700	12,739	49,250	20,180	118,200	57,347	8.6
NG120XP0	11.9998	14.0003	12.742	13.258	21,340	13,315	53,350	21,280	138,700	64,935	9.3
NG140XP0	13.9998	16.0003	14.742	15.258	24,620	14,404	61,560	23,410	184,700	81,056	10.8
NG160XP0	15.9998	18.0003	16.742	17.258	27,910	15,425	69,770	25,450	237,200	98,373	12.3
NG180XP0	17.9998	20.0003	18.742	19.258	31,190	16,386	77,980	27,410	296,300	116,793	13.7
NG200XP0	19.9998	22.0003	20.742	21.258	34,470	17,293	86,180	29,300	362,000	136,238	15.8
NG220XP0	21.9998	24.0003	22.742	23.258	37,760	18,152	94,390	31,130	434,200	156,625	17.3
NG250XP0	24.9998	27.0003	25.742	26.258	42,680	19,360	106,700	33,780	554,900	188,838	19.5
NG300XP0	29.9998	32.0003	30.742	31.258	50,890	21,200	127,200	37,980	788,800	246,541	23.3
NG350XP0	34.9998	37.0003	35.742	36.258	59,100	22,845	147,700	41,970	1,064,000	308,527	27.1
NG400XP0	39.9998	42.0003	40.742	41.258	67,310	24,332	168,300	45,770	1,380,000	374,256	30.8

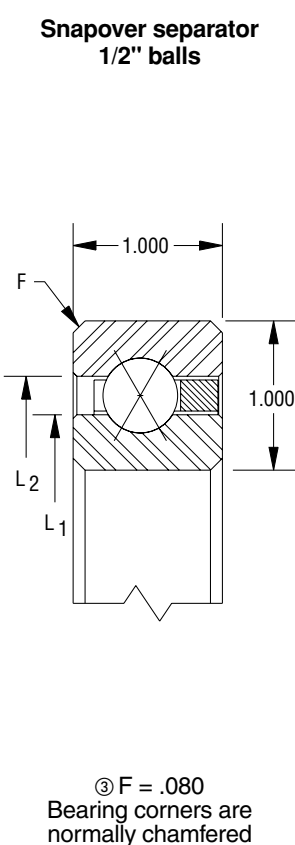

① Capacities listed are not simultaneous. For combined loading see discussion of Bearing Selection and Load Analysis. Dynamic capacities are based upon 1 million revolutions of L10 life. Published capacities do not apply to hybrid series bearings P, X, and Y - contact KAYDON product engineering for values.
 ② Static capacities are non-brinell limits based on rigid support from the shaft and housing.
 ③ "F" is the maximum shaft or housing fillet radius the bearing corners will clear.
 * Contact KAYDON for lead time and minimum purchase requirement.

Stainless Steel Bearings (Material Code S)

KAYDON stainless steel bearings are used where high precision and corrosion resistance are required.

In today's manufacturing environment, bearings are often required:

- to operate in close proximity to corrosive chemicals
- to operate with lubricants which do not protect against corrosion
- to be ready-to-use, ultra-clean bearings with no preservative on them

Because any of these requirements would disqualify the use of standard 52100 steel material, KAYDON addressed these issues by offering REALI-SLIM® thin-section bearings in AISI 440C stainless steel. This steel meets the minimum 58 HRc hardness level and can support the same loading as does 52100 chrome steel.

All bearings made of this material also utilize balls made of AISI 440C stainless steel.

Stainless Steel REALI-SLIM® thin-section bearings minimize the surface degradation and particulate formation so common in harsh environment applications.

They are available:

- in AISI 440C stainless steel races
- with brass or non-metallic separators
- with either stainless steel or ceramic balls
- in popular sizes
- in either radial contact "C," angular contact "A," or four-point contact "X" configurations



Stainless Steel REALI-SLIM® Bearings

Type A Angular Contact

SAA SERIES (3/16" cross-section)										
KAYDON Bearing Number	Dimensions in Inches					Capacities in Pounds ^①				Weight in Pounds
	Bore	Outside Dia.	Land Dia. L ₁	Land Dia. L ₂	C'Bore Dia. L ₃	Radial		Thrust		
						Static ^②	Dyn.	Static ^②	Dyn.	
*SAA10AG0	1.000	1.375	1.140	1.235	1.274	340	194	970	450	.025
*SAA15AG0	1.500	1.875	1.640	1.735	1.774	480	238	1,380	560	.038
*SAA17AG0	1.750	2.125	1.890	1.985	2.024	530	251	1,520	600	.045

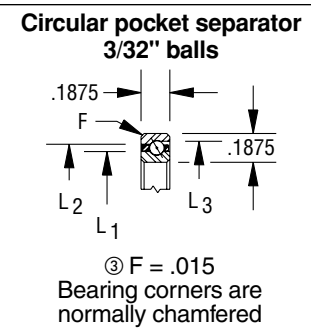

SA SERIES (1/4" cross-section)										
KAYDON Bearing Number	Dimensions in Inches					Capacities in Pounds ^①				Weight in Pounds
	Bore	Outside Dia.	Land Dia. L ₁	Land Dia. L ₂	C'Bore Dia. L ₃	Radial		Thrust		
						Static ^②	Dyn.	Static ^②	Dyn.	
*SA020AR0	2.000	2.500	2.186	2.314	2.369	790	405	2,280	960	.10
*SA025AR0	2.500	3.000	2.686	2.814	2.869	960	459	2,780	1,100	.12
*SA030AR0	3.000	3.500	3.186	3.314	3.367	1,140	507	3,290	1,230	.14
*SA035AR0	3.500	4.000	3.686	3.814	3.867	1,310	552	3,790	1,350	.17
*SA040AR0	4.000	4.500	4.186	4.314	4.367	1,490	595	4,300	1,470	.19

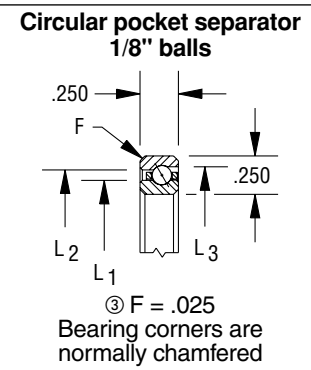

SB SERIES (5/16" cross-section)										
KAYDON Bearing Number	Dimensions in Inches					Capacities in Pounds ^①				Weight in Pounds
	Bore	Outside Dia.	Land Dia. L ₁	Land Dia. L ₂	C'Bore Dia. L ₃	Radial		Thrust		
						Static ^②	Dyn.	Static ^②	Dyn.	
*SB020AR0	2.000	2.625	2.231	2.393	2.464	1,090	601	3,150	1,380	.15
*SB025AR0	2.500	3.125	2.731	2.893	2.964	1,340	675	3,860	1,590	.19
*SB030AR0	3.000	3.625	3.231	3.393	3.462	1,550	734	4,470	1,750	.22
*SB035AR0	3.500	4.125	3.731	3.893	3.962	1,790	801	5,180	1,930	.27
*SB040AR0	4.000	4.625	4.231	4.393	4.460	2,040	865	5,890	2,100	.30

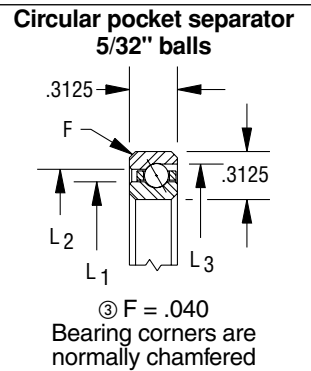

① Capacities listed are not simultaneous. For combined loading see discussion of Bearing Selection and Load Analysis. Dynamic capacities are based upon 1 million revolutions of L10 life. Published capacities do not apply to hybrid series bearings P, X, and Y - contact KAYDON product engineering for values.

② Static capacities are non-brinell limits based on rigid support from the shaft and housing.

③ "F" is the maximum shaft or housing fillet radius the bearing corners will clear.

* Contact KAYDON for lead time and minimum purchase requirement.

Stainless Steel REALI-SLIM® Bearings

Type C Radial Contact

SAA SERIES (3/16" cross section)							
KAYDON Bearing Number	Dimensions in Inches				Radial Capacities in Pounds ^①		Weight in Pounds
	Bore	Outside Dia.	Land Dia. L ₁	Land Dia. L ₂	Static ^②	Dyn.	
*SAA10CLO	1.000	1.375	1.140	1.235	290	188	.026
*SAA15CLO	1.500	1.875	1.640	1.735	400	225	.039
*SAA17CLO	1.750	2.125	1.890	1.985	460	242	.045

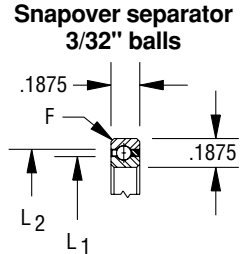

Snapover separator 3/32" balls

③ F = .015
Bearing corners are normally chamfered

SA SERIES (1/4" cross section)							
KAYDON Bearing Number	Dimensions in Inches				Radial Capacities in Pounds ^①		Weight in Pounds
	Bore	Outside Dia.	Land Dia. L ₁	Land Dia. L ₂	Static ^②	Dyn.	
*SA020CP0	2.000	2.500	2.186	2.314	680	393	.10
*SA025CP0	2.500	3.000	2.686	2.814	830	442	.13
*SA030CP0	3.000	3.500	3.186	3.314	990	487	.15
*SA035CP0	3.500	4.000	3.686	3.814	1,140	530	.18
*SA040CP0	4.000	4.500	4.186	4.314	1,290	571	.19

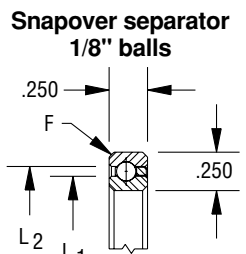

Snapover separator 1/8" balls

③ F = .025
Bearing corners are normally chamfered

SB SERIES (5/16" cross section)							
KAYDON Bearing Number	Dimensions in Inches				Radial Capacities in Pounds ^①		Weight in Pounds
	Bore	Outside Dia.	Land Dia. L ₁	Land Dia. L ₂	Static ^②	Dyn.	
*SB020CP0	2.000	2.625	2.231	2.393	930	577	.16
*SB025CP0	2.500	3.125	2.731	2.893	1,140	644	.20
*SB030CP0	3.000	3.625	3.231	3.393	1,340	707	.24
*SB035CP0	3.500	4.125	3.731	3.893	1,540	767	.27
*SB040CP0	4.000	4.625	4.231	4.393	1,750	825	.30

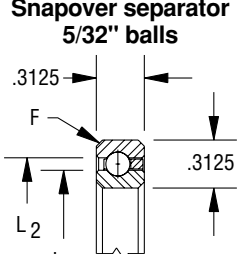

Snapover separator 5/32" balls

③ F = .040
Bearing corners are normally chamfered

① Capacities listed are not simultaneous. For combined loading see discussion of Bearing Selection and Load Analysis. Dynamic capacities are based upon 1 million revolutions of L10 life. Published capacities do not apply to hybrid series bearings P, X, and Y - contact KAYDON product engineering for values.

② Static capacities are non-brinell limits based on rigid support from the shaft and housing.

③ "F" is the maximum shaft or housing fillet radius the bearing corners will clear.

* Contact KAYDON for lead time and minimum purchase requirement.

Stainless Steel REALI-SLIM® Bearings

Type X Four-Point Contact

SERIES SAA (3/16" cross section)											
KAYDON Bearing Number	Dimensions in Inches				Capacities ^①						Weight in Pounds
	Bore	Outside Dia.	Land Dia. L ₁	Land Dia. L ₂	Radial (lbs)		Thrust (lbs)		Moment (in-lbs)		
					Static ^②	Dyn.	Static ^②	Dyn.	Static ^②	Dyn.	
*SAA10XL0	1.000	1.375	1.140	1.235	290	247	730	370	170	110	.026
*SAA15XL0	1.500	1.875	1.640	1.735	400	296	1,000	460	340	187	.039
*SAA17XL0	1.750	2.125	1.890	1.985	460	319	1,140	500	440	232	.045

Snapover separator
3/32" balls

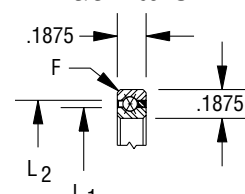

③ F = .015
Bearing corners are normally chamfered

SERIES SA (1/4" cross section)											
KAYDON Bearing Number	Dimensions in Inches				Capacities ^①						Weight in Pounds
	Bore	Outside Dia.	Land Dia. L ₁	Land Dia. L ₂	Radial (lbs)		Thrust (lbs)		Moment (in-lbs)		
					Static ^②	Dyn.	Static ^②	Dyn.	Static ^②	Dyn.	
*SA020XP0	2.000	2.500	2.186	2.314	680	514	1,710	790	770	434	.10
*SA025XP0	2.500	3.000	2.686	2.814	830	583	2,090	910	1,150	601	.13
*SA030XP0	3.000	3.500	3.186	3.314	990	643	2,470	1,010	1,600	785	.15
*SA035XP0	3.500	4.000	3.686	3.814	1,140	701	2,850	1,110	2,130	986	.18
*SA040XP0	4.000	4.500	4.186	4.314	1,290	756	3,220	1,210	2,740	1,205	.19

Snapover separator
1/8" balls

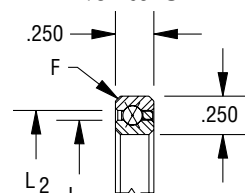

③ F = .025
Bearing corners are normally chamfered

SERIES SB (5/16" cross section)											
KAYDON Bearing Number	Dimensions in Inches				Capacities ^①						Weight in Pounds
	Bore	Outside Dia.	Land Dia. L ₁	Land Dia. L ₂	Radial (lbs)		Thrust (lbs)		Moment (in-lbs)		
					Static ^②	Dyn.	Static ^②	Dyn.	Static ^②	Dyn.	
*SB020XP0	2.000	2.625	2.231	2.393	930	758	2,340	1,130	1,080	658	.16
*SB025XP0	2.500	3.125	2.731	2.893	1,140	848	2,840	1,290	1,600	895	.19
*SB030XP0	3.000	3.625	3.231	3.393	1,340	933	3,350	1,440	2,220	1,159	.24
*SB035XP0	3.500	4.125	3.731	3.893	1,540	1,014	3,860	1,590	2,940	1,450	.27
*SB040XP0	4.000	4.625	4.231	4.393	1,750	1,091	4,370	1,720	3,770	1,764	.30

Snapover separator
5/32" balls

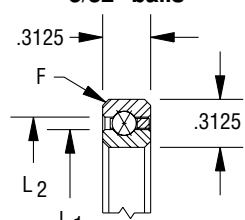

③ F = .040
Bearing corners are normally chamfered

① Capacities listed are not simultaneous. For combined loading see discussion of Bearing Selection and Load Analysis. Dynamic capacities are based upon 1 million revolutions of L10 life. Published capacities do not apply to hybrid series bearings P, X, and Y - contact KAYDON product engineering for values.

② Static capacities are non-brinell limits based on rigid support from the shaft and housing.

③ "F" is the maximum shaft or housing fillet radius the bearing corners will clear.

* Contact KAYDON for lead time and minimum purchase requirement.

REALI-SLIM MM™ Metric Series Bearings

KAYDON created the thin-section bearing standard of the industry in 1954 based on inch sizes. The REALI-SLIM® inch-standard bearing is still the most widely used thin-section bearing in the world.

However, for those applications that require metric envelope dimensions or for dimensional interchangeability with other products, KAYDON offers the REALI-SLIM MM™ series of bearings.

These bearings are offered:

- in cross sections of 8, 13, and 20mm
- with bore diameters ranging from 20mm to 360mm
- with many of the same options found on standard REALI-SLIM® bearings

The REALI-SLIM MM™ series may also be customized for special applications with options such as:

- ceramic balls
- special lubes
- integral seals

Consult KAYDON engineering or your KAYDON representative for details on customization.



Download REALI-DESIGN MM™ software from our website www.kaydonbearings.com to obtain specific load/life and other performance data not shown here.

CONTACT KAYDON AT—

KAYDON Corporation • Muskegon, Michigan 49443
Telephone: 231/755-3741 • Fax: 231/759-4102

NEED SERVICE FAST?

1-800-514-3066
Website: www.kaydonbearings.com

REALI-SLIM MM™ Metric Series Bearing Selections Type A Angular Contact

How to identify REALI-SLIM MM™ Bearings using our part number code:

Standard and optional metric REALI-SLIM® bearings are marked for complete identification with a 9- or 10-digit part number. Positions 1–9 identify materials, size, type, separator type, and precision. Position 10 (optional) identifies non-standard internal fit, either preload or clearance. Custom and proprietary bearings cannot be identified by code, and are marked only with a 9-digit number.

Figure 2-10

Position	1	2	3	4	5	6	7	8	9	10
Nomenclature	Material	Bore (mm)			Width(mm)		Type	Separator	Precision	Internal Fit
Example	K	0	8	0	0	8	X	P	0	K

Explanation of position numbers:

- | | | |
|---|---|---|
| 1) K = AISI 52100 steel
S = AISI 440C stainless
N = ENDURAKOTE® plating | 8) P = Standard formed ring snap-over type
R = Standard formed ring circular pocket type | 10) empty = Standard (See page 90)
A = .0000 to .0127 mm clearance
K = .0000 to .0127 mm preload
L = .0000 to .0254 mm preload
Z = other clearance or preload not specified above |
| 7) = A: Angular contact
C: Radial contact
X: Four-point contact | 9) 0 = Precision Class 1 (ABEC 1F) standard | |

8mm SERIES											Circular pocket separator 5/32" (inch) balls
KAYDON Bearing Number	Dimensions					Capacity ^①				Weight (kg)	
	Size (mm)		Land Diameters (mm)			Radial (kg)		Axial (kg)			
	Bore	Outside Dia.	Land Dia. L ₁	Land Dia. L ₂	Land Dia. L ₃	Static ^②	Dyn.	Static ^②	Dyn.		
K02508AR0	25	41	30.9	35.1	37.2	372	272	1073	561	0.06	
K05008AR0	50	66	55.9	60.1	62.2	656	367	1894	819	0.08	
K06008AR0	60	76	65.9	70.1	72.2	787	408	2273	925	0.09	
K07008AR0	70	86	75.9	80.1	82.2	896	440	2588	1009	0.10	
K08008AR0	80	96	85.9	90.1	92.2	1006	470	2903	1090	0.12	
K09008AR0	90	106	95.9	100.1	102.2	1137	505	3282	1182	0.13	
K10008AR0	100	116	105.9	110.1	112.2	1246	533	3598	1257	0.14	
K11008AR0	110	126	115.9	120.1	122.2	1356	561	3914	1329	0.15	
K12008AR0	120	136	125.9	130.1	132.2	1465	587	4229	1400	0.16	
K13008AR0	130	146	135.9	140.1	142.2	1596	618	4608	1482	0.17	
K14008AR0	140	156	145.9	150.1	152.2	1706	643	4923	1549	0.18	
K15008AR0	150	166	155.9	160.1	162.2	1815	667	5239	1615	0.20	
K16008AR0	160	176	165.9	170.1	172.2	1946	696	5618	1691	0.20	
K17008AR0	170	186	175.9	180.1	182.1	2055	720	5933	1754	0.21	
K18008AR0	180	196	185.9	190.1	192.1	2165	742	6249	1816	0.22	
*K19008AR0	190	206	195.9	200.1	202.1	2296	769	6628	1889	0.23	
K20008AR0	200	216	205.9	210.1	212.1	2405	791	6944	1948	0.23	
K25008AR0	250	266	255.9	260.1	262.1	2974	897	8585	2244	0.28	
K30008AR0	300	316	305.9	310.1	312.1	3564	999	10289	2532	0.33	
K32008AR0	320	336	325.9	330.1	332.1	3805	1039	10983	2645	0.36	
K34008AR0	340	356	345.9	350.1	352.1	4023	1073	11614	2745	0.38	
K36008AR0	360	376	365.9	370.1	372.1	4264	1110	12309	2854	0.40	

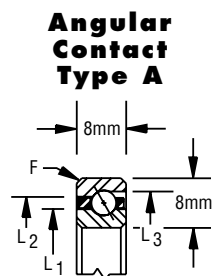

③ F = 0.8
Bearing corners are normally chamfered

① Capacities listed are not simultaneous. For combined loading see discussion of Bearing Selection and Load Analysis. Dynamic capacities are based upon 1 million revolutions of L10 life. Published capacities do not apply to hybrid series bearings P, X, and Y - contact KAYDON product engineering for values.
 ② Static capacities are non-brinell limits based on rigid support from the shaft and housing.
 ③ "F" is the maximum shaft or housing fillet radius the bearing corners will clear.
 * Contact KAYDON for lead time and minimum purchase requirement. All dimensions in millimeters.

REALI-SLIM MM™ Metric Series Bearing Selections

Type A Angular Contact

13mm SERIES										
KAYDON Bearing Number	Dimensions					Capacity ^①				Weight (kg)
	Size (mm)		Land Diameters (mm)			Radial (kg)		Axial (kg)		
	Bore	Outside Dia.	Land Dia. L ₁	Land Dia. L ₂	Land Dia. L ₃	Static ^②	Dyn.	Static ^②	Dyn.	
*K02513ARO	25	51	34.7	41.3	44.7	616	554	1778	1075	0.13
*K05013ARO	50	76	59.7	66.3	69.6	1064	725	3070	1547	0.20
*K06013ARO	60	86	69.7	76.3	79.6	1232	782	3555	1706	0.22
K07013ARO	70	96	79.7	86.3	89.6	1456	860	4201	1906	0.25
*K08013ARO	80	106	89.7	96.3	99.6	1623	913	4686	2050	0.28
*K09013ARO	90	116	99.7	106.3	109.6	1791	964	5171	2190	0.31
*K10013ARO	100	126	109.7	116.3	119.6	1959	1013	5656	2324	0.34
*K11013ARO	110	136	119.7	126.3	129.6	2127	1061	6141	2455	0.37
*K12013ARO	120	146	129.7	136.3	139.6	2295	1108	6625	2583	0.39
*K13013ARO	130	156	139.7	146.3	149.6	2519	1171	7272	2748	0.42
*K14013ARO	140	166	149.7	156.3	159.5	2687	1215	7757	2869	0.45
*K15013ARO	150	176	159.7	166.3	169.5	2855	1258	8241	2987	0.48
*K16013ARO	160	186	169.7	176.3	179.5	3023	1301	8726	3104	0.51
K17013ARO	170	196	179.7	186.3	189.5	3191	1342	9211	3217	0.54
*K18013ARO	180	206	189.7	196.3	199.5	3359	1382	9696	3329	0.56
K19013ARO	190	216	199.7	206.3	209.5	3527	1422	10181	3439	0.59
*K20013ARO	200	226	209.7	216.3	219.4	3750	1476	10827	3583	0.62
*K25013ARO	250	276	259.7	266.3	269.4	4590	1659	13251	4100	0.76
*K30013ARO	300	326	309.7	316.3	319.3	5486	1840	15837	4618	0.90
*K32013ARO	320	346	329.7	336.3	339.3	5822	1904	16806	4804	0.96
*K34013ARO	340	366	349.7	356.3	359.2	6213	1978	17937	5017	1.02
*K36013ARO	360	386	369.7	376.3	379.2	6550	2038	18907	5196	1.07

Circular pocket separator
1/4" (inch) balls

Angular Contact Type A

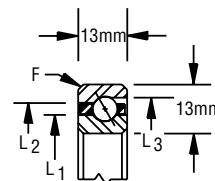

③ F = 1.5
Bearing corners are normally chamfered

20mm SERIES										
KAYDON Bearing Number	Dimensions					Capacity ^①				Weight (kg)
	Size (mm)		Land Diameters (mm)			Radial (kg)		Axial (kg)		
	Bore	Outside Dia.	Land Dia. L ₁	Land Dia. L ₂	Land Dia. L ₃	Static ^②	Dyn.	Static ^②	Dyn.	
*K02520ARO	25	65	40.0	50.0	55	1134	1155	3272	2115	0.31
*K05020ARO	50	90	65.0	75.0	80	1889	1460	5454	2973	0.49
*K06020ARO	60	100	75.0	85.0	90	2141	1547	6181	3231	0.56
*K07020ARO	70	110	85.0	95.0	100	2393	1633	6908	3480	0.62
*K08020ARO	80	120	95.0	105.0	110	2645	1717	7635	3720	0.69
*K09020ARO	90	130	105.0	115.0	120	3023	1851	8726	4067	0.77
*K10020ARO	100	140	115.0	125.0	130	3275	1929	9453	4290	0.84
*K11020ARO	110	150	125.0	135.0	140	3527	2005	10181	4507	0.91
*K12020ARO	120	160	135.0	145.0	150	3778	2080	10908	4719	0.97
*K13020ARO	130	170	145.0	155.0	160	4030	2154	11635	4927	1.04
*K14020ARO	140	180	155.0	165.0	170	4282	2226	12362	5130	1.11
K15020ARO	150	190	165.0	175.0	180	4660	2339	13453	5427	1.19
K16020ARO	160	200	175.0	185.0	190	4912	2407	14180	5621	1.26
K17020ARO	170	210	185.0	195.0	200	5146	2474	14907	5811	1.32
K18020ARO	180	220	195.0	205.0	210	5416	2540	15634	5999	1.39
*K19020ARO	190	230	205.0	215.0	220	5668	2605	16361	6183	1.46
K20020ARO	200	240	215.0	225.0	230	6045	2706	17452	6455	1.54
K25020ARO	250	290	265.0	275.0	280	7431	3041	21452	7408	1.89
K30020ARO	300	340	315.0	325.0	330	8691	3317	25088	8222	2.23
*K32020ARO	320	360	335.0	345.0	350	9321	3454	26906	8615	2.37
*K34020ARO	340	380	355.0	365.0	370	9824	3556	28360	8923	2.51
*K36020ARO	360	400	375.0	385.0	390	10454	3685	30178	9300	2.66

Circular pocket separator
3/8" (inch) balls

Angular Contact Type A

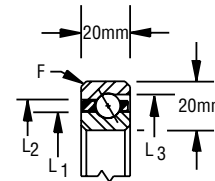

③ F = 1.5
Bearing corners are normally chamfered

① Capacities listed are not simultaneous. For combined loading see discussion of Bearing Selection and Load Analysis. Dynamic capacities are based upon 1 million revolutions of L10 life. Published capacities do not apply to hybrid series bearings P, X, and Y - contact KAYDON product engineering for values.
 ② Static capacities are non-brinell limits based on rigid support from the shaft and housing.
 ③ "F" is the maximum shaft or housing fillet radius the bearing corners will clear.
 * Contact KAYDON for lead time and minimum purchase requirement. All dimensions in millimeters.

REALI-SLIM MM™ Metric Series Bearing Selections

Type C Radial Contact

8mm SERIES								Snapover separator 5/32" (inch) balls
KAYDON Bearing Number	Dimensions				Capacity ^①		Weight (kg)	
	Size (mm)		Land Diameters (mm)		Radial (kg)			
	Bore	Outside Dia.	Land Dia. L ₁	Land Dia. L ₂	Static ^②	Dynamic		
K02508CP0	25	41	30.9	35.1	303	255	0.06	
K05008CP0	50	66	55.9	60.1	556	350	0.08	
K06008CP0	60	76	65.9	70.1	656	384	0.09	
K07008CP0	70	86	75.9	80.1	758	417	0.10	
K08008CP0	80	96	85.9	90.1	859	448	0.11	
K09008CP0	90	106	95.9	100.1	959	478	0.13	
K10008CP0	100	116	105.9	110.1	1061	507	0.14	
K11008CP0	110	126	115.9	120.1	1162	534	0.15	
K12008CP0	120	136	125.9	130.1	1262	561	0.16	
K13008CP0	130	146	135.9	140.1	1364	588	0.17	
K14008CP0	140	156	145.9	150.1	1465	613	0.18	
K15008CP0	150	166	155.9	160.1	1565	638	0.20	
K16008CP0	160	176	165.9	170.1	1666	662	0.20	
K17008CP0	170	186	175.9	180.1	1767	686	0.20	
K18008CP0	180	196	185.9	190.1	1868	709	0.21	
*K19008CP0	190	206	195.9	200.1	1944	725	0.21	
K20008CP0	200	216	205.9	210.1	2045	748	0.22	
K25008CP0	250	266	255.9	260.1	2550	853	0.28	
K30008CP0	300	316	305.9	310.1	3055	949	0.35	
K32008CP0	320	336	325.9	330.1	3257	985	0.39	
K34008CP0	340	356	345.9	350.1	3459	1016	0.42	
K36008CP0	360	376	365.9	370.1	3636	1050	0.46	

**Conrad
Assembly
Type C**

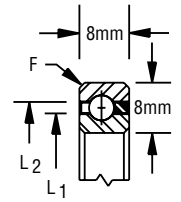

③ F = 0.8
Bearing corners are normally chamfered

① Capacities listed are not simultaneous. For combined loading see discussion of Bearing Selection and Load Analysis. Dynamic capacities are based upon 1 million revolutions of L10 life. Published capacities do not apply to hybrid series bearings P, X, and Y - contact KAYDON product engineering for values.
 ② Static capacities are non-brinell limits based on rigid support from the shaft and housing.
 ③ "F" is the maximum shaft or housing fillet radius the bearing corners will clear.
 * Contact KAYDON for lead time and minimum purchase requirement. All dimensions in millimeters.

CONTACT KAYDON AT—
 KAYDON Corporation • Muskegon, Michigan 49443
 Telephone: 231/755-3741 • Fax: 231/759-4102
NEED SERVICE FAST?
 1-800-514-3066
 Website: www.kaydonbearings.com

REALI-SLIM MM™ Metric Series Bearing Selections

Type C Radial Contact

13mm SERIES								Snapover separator 1/4" (inch) balls
KAYDON Bearing Number	Dimensions				Capacity ^①		Weight (kg)	
	Size (mm)		Land Diameters (mm)		Radial (kg)			
	Bore	Outside Dia.	Land Dia. L ₁	Land Dia. L ₂	Static ^②	Dynamic		
*K02513CP0	25	51	34.7	41.3	517	535	0.11	
*K05013CP0	50	76	59.7	66.3	905	697	0.18	
*K06013CP0	60	86	69.7	76.3	1099	775	0.21	
K07013CP0	70	96	79.7	86.3	1228	819	0.24	
*K08013CP0	80	106	89.7	96.3	1358	862	0.26	
*K09013CP0	90	116	99.7	106.3	1551	931	0.29	
*K10013CP0	100	126	109.7	116.3	1681	971	0.32	
*K11013CP0	110	136	119.7	126.3	1875	1035	0.35	
*K12013CP0	120	146	129.7	136.3	2004	1073	0.38	
*K13013CP0	130	156	139.7	146.3	2133	1110	0.41	
*K14013CP0	140	166	149.7	156.3	2327	1169	0.44	
*K15013CP0	150	176	159.7	166.3	2456	1204	0.46	
*K16013CP0	160	186	169.7	176.3	2586	1239	0.49	
K17013CP0	170	196	179.7	186.3	2780	1294	0.52	
*K18013CP0	180	206	189.7	196.3	2909	1327	0.55	
K19013CP0	190	216	199.7	206.3	3038	1360	0.58	
*K20013CP0	200	226	209.7	216.3	3232	1411	0.61	
*K25013CP0	250	276	259.7	266.3	4008	1598	0.75	
*K30013CP0	300	326	309.7	316.3	4719	1754	0.89	
*K32013CP0	320	346	329.7	336.3	5042	1823	0.95	
*K34013CP0	340	366	349.7	356.3	5365	1889	1.01	
*K36013CP0	360	386	369.7	376.3	5688	1954	1.06	

**Conrad
Assembly
Type C**

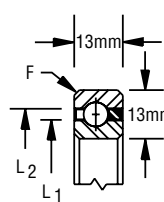

③ F = 1.5
Bearing corners are normally chamfered

20mm SERIES								Snapover separator 3/8" (inch) balls
KAYDON Bearing Number	Dimensions				Capacity ^①		Weight (kg)	
	Size (mm)		Land Diameters (mm)		Radial (kg)			
	Bore	Outside Dia.	Land Dia. L ₁	Land Dia. L ₂	Static ^②	Dynamic		
*K02520CP0	25	65	40.0	50.0	1018	1178	0.34	
*K05020CP0	50	90	65.0	75.0	1600	1410	0.51	
*K06020CP0	60	100	75.0	85.0	1745	1452	0.58	
*K07020CP0	70	110	85.0	95.0	2036	1573	0.65	
*K08020CP0	80	120	95.0	105.0	2181	1617	0.72	
*K09020CP0	90	130	105.0	115.0	2473	1730	0.80	
*K10020CP0	100	140	115.0	125.0	2618	1773	0.86	
*K11020CP0	110	150	125.0	135.0	2909	1880	0.94	
*K12020CP0	120	160	135.0	145.0	3200	1982	1.01	
*K13020CP0	130	170	145.0	155.0	3345	2023	1.08	
*K14020CP0	140	180	155.0	165.0	3636	2121	1.15	
K15020CP0	150	190	165.0	175.0	3781	2161	1.20	
K16020CP0	160	200	175.0	185.0	4072	2254	1.30	
K17020CP0	170	210	185.0	195.0	4363	2293	1.40	
K18020CP0	180	220	195.0	205.0	4508	2383	1.50	
*K19020CP0	190	230	205.0	215.0	4800	2470	1.50	
K20020CP0	200	240	215.0	225.0	4945	2507	1.60	
K25020CP0	250	290	265.0	275.0	6108	2821	2.10	
K30020CP0	300	340	315.0	325.0	7272	3111	2.30	
*K32020CP0	320	360	335.0	345.0	7708	3213	2.42	
*K34020CP0	340	380	355.0	365.0	8144	3312	2.54	
*K36020CP0	360	400	375.0	385.0	8581	3408	2.70	

**Conrad
Assembly
Type C**

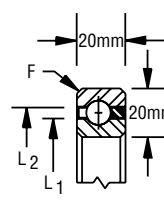

③ F = 1.5
Bearing corners are normally chamfered

① Capacities listed are not simultaneous. For combined loading see discussion of Bearing Selection and Load Analysis. Dynamic capacities are based upon 1 million revolutions of L10 life. Published capacities do not apply to hybrid series bearings P, X, and Y - contact KAYDON product engineering for values.
 ② Static capacities are non-brinell limits based on rigid support from the shaft and housing.
 ③ "F" is the maximum shaft or housing fillet radius the bearing corners will clear.
 * Contact KAYDON for lead time and minimum purchase requirement. All dimensions in millimeters.

REALI-SLIM MM™ Metric Series Bearing Selections

Type X Four-Point Contact

8mm SERIES												Snapover separator 5/32" (inch) balls
KAYDON Bearing Number	Dimensions				Capacity ^①						Weight (kg)	
	Size (mm)		Land Diameters (mm)		Radial (kg)		Axial (kg)		Moment (Nm)			
	Bore	Outside Dia.	Land Dia. L ₁	Land Dia. L ₂	Static ^②	Dyn.	Static ^②	Dyn.	Static ^②	Dyn.		
K02508XP0	25	41	30.9	35.1	334	331	758	469	49	40	0.04	
K05008XP0	50	66	55.9	60.1	555	460	1389	666	158	98	0.07	
K06008XP0	60	76	65.9	70.1	656	506	1641	745	219	127	0.09	
K07008XP0	70	86	75.9	80.1	757	549	1894	819	290	158	0.10	
K08008XP0	80	96	85.9	90.1	859	591	2146	890	370	191	0.11	
K09008XP0	90	106	95.9	100.1	959	631	2399	959	461	228	0.13	
K10008XP0	100	116	105.9	110.1	1060	670	2651	1025	562	266	0.14	
K11008XP0	110	126	115.9	120.1	1162	707	2903	1090	672	307	0.15	
K12008XP0	120	136	125.9	130.1	1262	743	3156	1152	792	350	0.16	
K13008XP0	130	146	135.9	140.1	1363	778	3409	1212	923	395	0.18	
K14008XP0	140	156	145.9	150.1	1465	812	3661	1271	1063	442	0.19	
K15008XP0	150	166	155.9	160.1	1565	846	3914	1329	1213	492	0.20	
K16008XP0	160	176	165.9	170.1	1666	878	4166	1386	1373	543	0.20	
K17008XP0	170	186	175.9	180.1	1767	910	4418	1441	1543	596	0.20	
K18008XP0	180	196	185.9	190.1	1868	941	4671	1495	1722	651	0.21	
*K19008XP0	190	206	195.9	200.1	1944	963	4860	1536	1888	701	0.21	
K20008XP0	200	216	205.9	210.1	2045	992	5113	1588	2086	759	0.22	
K25008XP0	250	266	255.9	260.1	2550	1133	6375	1840	3226	1075	0.28	
K30008XP0	300	316	305.9	310.1	3055	1261	7638	2076	4614	1429	0.35	
K32008XP0	320	336	325.9	330.1	3257	1310	8143	2166	5238	1580	0.39	
K34008XP0	340	356	345.9	350.1	3459	1350	8648	2255	5859	1728	0.42	
K36008XP0	360	376	365.9	370.1	3636	1396	9089	2330	6561	1890	0.46	

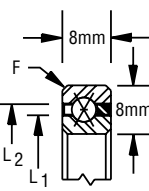

4 Point Contact Type X

③ F = 0.8
Bearing corners are normally chamfered

① Capacities listed are not simultaneous. For combined loading see discussion of Bearing Selection and Load Analysis. Dynamic capacities are based upon 1 million revolutions of L10 life. Published capacities do not apply to hybrid series bearings P, X, and Y - contact KAYDON product engineering for values.
 ② Static capacities are non-brinell limits based on rigid support from the shaft and housing.
 ③ "F" is the maximum shaft or housing fillet radius the bearing corners will clear.
 * Contact KAYDON for lead time and minimum purchase requirement. All dimensions in millimeters.

CONTACT KAYDON AT—
 KAYDON Corporation • Muskegon, Michigan 49443
 Telephone: 231/755-3741 • Fax: 231/759-4102

NEED SERVICE FAST?
 1-800-514-3066
 Website: www.kaydonbearings.com

REALI-SLIM MM™ Metric Series Bearing Selections

Type X Four-Point Contact

13mm SERIES												Snapover separator 1/4" (inch) balls
KAYDON Bearing Number	Dimensions				Capacity ^①						Weight (kg)	
	Size (mm)		Land Diameters (mm)		Radial (kg)		Axial (kg)		Moment (Nm)			
	Bore	Outside Dia.	Land Dia. L ₁	Land Dia. L ₂	Static ^②	Dyn.	Static ^②	Dyn.	Static ^②	Dyn.		
*K02513XP0	25	51	34.7	41.3	696	689	1293	869	96	96	0.13	
*K05013XP0	50	76	59.7	66.3	919	910	2263	1226	280	211	0.20	
*K06013XP0	60	86	69.7	76.3	1099	1014	2747	1436	393	272	0.23	
*K07013XP0	70	96	79.7	86.3	1228	1074	3070	1547	500	328	0.26	
*K08013XP0	80	106	89.7	96.3	1358	1133	3393	1653	619	388	0.28	
*K09013XP0	90	116	99.7	106.3	1551	1224	3878	1808	784	464	0.31	
*K10013XP0	100	126	109.7	116.3	1681	1279	4201	1906	931	532	0.34	
*K11013XP0	110	136	119.7	126.3	1875	1364	4686	2050	1131	617	0.37	
*K12013XP0	120	146	129.7	136.3	2006	1415	5010	2144	1307	693	0.40	
*K13013XP0	130	156	139.7	146.3	2133	1466	5333	2235	1496	771	0.43	
*K14013XP0	140	166	149.7	156.3	2327	1544	5817	2368	1746	869	0.46	
*K15013XP0	150	176	159.7	166.3	2456	1592	6141	2455	1963	954	0.48	
*K16013XP0	160	186	169.7	176.3	2586	1639	6464	2541	2193	1043	0.51	
*K17013XP0	170	196	179.7	186.3	2780	1711	6949	2666	2494	1152	0.54	
*K18013XP0	180	206	189.7	196.3	2909	1756	7272	2748	2753	1247	0.57	
K19013XP0	190	216	199.7	206.3	3038	1800	7595	2829	3024	1344	0.60	
*K20013XP0	200	226	209.7	216.3	3232	1868	8080	2948	3375	1464	0.63	
*K25013XP0	250	276	259.7	266.3	4008	2119	10019	3403	5168	2050	0.77	
*K30013XP0	300	326	309.7	316.3	4719	2327	11796	3794	7242	2680	0.91	
*K32013XP0	320	346	329.7	336.3	5042	2419	12605	3966	8232	2963	0.97	
*K34013XP0	340	366	349.7	356.3	5365	2508	13412	4133	9286	3257	1.02	
*K36013XP0	360	386	369.7	376.3	5688	2594	14220	4298	10403	3560	1.08	

**4 Point
Contact
Type X**

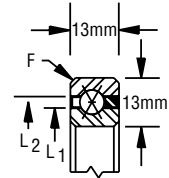

③ F = 1.5
Bearing corners are normally chamfered

20mm SERIES												Snapover separator 3/8" (inch) balls
KAYDON Bearing Number	Dimensions				Capacity ^①						Weight (kg)	
	Size (mm)		Land Diameters (mm)		Radial (kg)		Axial (kg)		Moment (Nm)			
	Bore	Outside Dia.	Land Dia. L ₁	Land Dia. L ₂	Static ^②	Dyn.	Static ^②	Dyn.	Static ^②	Dyn.		
*K02520XP0	25	65	40.0	50.0	1518	1503	2545	1789	225	225	0.34	
*K05020XP0	50	90	65.0	75.0	1845	1827	3999	2418	549	470	0.52	
*K06020XP0	60	100	75.0	85.0	1906	1887	4363	2562	685	556	0.59	
*K07020XP0	70	110	85.0	95.0	2071	2050	5090	2839	899	679	0.66	
*K08020XP0	80	120	95.0	105.0	2181	2111	5454	2973	1070	777	0.73	
*K09020XP0	90	130	105.0	115.0	2473	2263	6181	3231	1334	916	0.80	
*K10020XP0	100	140	115.0	125.0	2618	2323	6545	3357	1540	1026	0.87	
*K11020XP0	110	150	125.0	135.0	2909	2466	7272	3601	1854	1179	0.94	
*K12020XP0	120	160	135.0	145.0	3200	2603	7999	3837	2196	1341	1.01	
*K13020XP0	130	170	145.0	155.0	3345	2660	8363	3953	2460	1468	1.07	
*K14020XP0	140	180	155.0	165.0	3636	2791	9090	4179	2852	1643	1.15	
K15020XP0	150	190	165.0	175.0	3781	2845	9453	4290	3152	1779	1.22	
K16020XP0	160	200	175.0	185.0	4072	2970	10180	4507	3594	1967	1.30	
K17020XP0	170	210	185.0	195.0	4363	3023	10907	4719	3929	2113	1.37	
K18020XP0	180	220	195.0	205.0	4508	3143	11271	4823	4421	2312	1.44	
*K19020XP0	190	230	205.0	215.0	4800	3260	11999	5029	4942	2519	1.51	
K20020XP0	200	240	215.0	225.0	4945	3309	12362	5130	5334	2678	1.57	
K25020XP0	250	290	265.0	275.0	6108	3731	15271	5906	8087	3706	2.10	
K30020XP0	300	340	315.0	325.0	7272	4119	18179	6633	11410	4849	2.30	
*K32020XP0	320	360	335.0	345.0	7708	4255	19270	6897	12850	5323	2.44	
*K34020XP0	340	380	355.0	365.0	8144	4388	20361	7154	14376	5812	2.58	
*K36020XP0	360	400	375.0	385.0	8581	4518	21452	7408	15988	6316	2.73	

**4 Point
Contact
Type X**

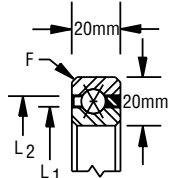

③ F = 1.5
Bearing corners are normally chamfered

① Capacities listed are not simultaneous. For combined loading see discussion of Bearing Selection and Load Analysis. Dynamic capacities are based upon 1 million revolutions of L10 life. Published capacities do not apply to hybrid series bearings P, X, and Y - contact KAYDON product engineering for values.

② Static capacities are non-brinell limits based on rigid support from the shaft and housing.

③ "F" is the maximum shaft or housing fillet radius the bearing corners will clear.

* Contact KAYDON for lead time and minimum purchase requirement. All dimensions in millimeters.

ULTRA-SLIM™ Thin-Section Bearings

Ideal for applications in robotics, inspection equipment, satellites, cameras... anywhere precise positioning and lightweight designs are critical.

At just 2.5 mm wide, ULTRA-SLIM™ bearings are available in bore sizes ranging from 35 mm to 170 mm for an array of applications.

Their compact profile allows you to use ULTRA-SLIM™ bearings in many highly confined spaces.

Precision-engineered ULTRA-SLIM™ bearings are made of stainless steel for corrosion resistance. They are available in angular contact (Type A), radial contact (Type C), and four-point contact (Type X) styles. (See selection charts at right.)

Hybrid bearings with ceramic balls are available upon request. These configurations are used often when lubrication is marginal or when lower wear generation and/or lower torque levels are required.

Figure 2-11

How to identify ULTRA-SLIM™ Bearings using our part number code

Position	1	2	3	4	5	6	7	8	9	10
Nomenclature	Material	Bore (mm)			Width(mm)		Type	Separator	Precision	Internal Fit
Example	S	1	1	0	0	3	C	S	0	K

Explanation of position numbers:

Position 1—Material

S = AISI 440C races and balls
(Standard for Series)

Positions 2, 3 and 4—Bore

Nominal bearing bore in mm.

Positions 5 and 6—Width

Nominal radial race width in mm.

Position 7—Bearing Type

A = Angular Contact
C = Radial Contact
X = Four-Point Contact

Position 8—Separator

S = Spacer balls
F = Full complement of load balls

Position 9—Precision

0 = KAYDON standard precision class

Position 10—Internal Fit

A = 0.000 - 0.130 mm clearance
C = 0.013 - 0.025 mm clearance
E = 0.025 - 0.510 mm clearance
K = 0.000 - 0.013 mm preload
M = 0.013 - 0.025 mm preload
empty = standard internal fitup if not specified

Performance and Application Considerations

ULTRA-SLIM™ bearings are unique in that their extremely thin cross section enables them to provide great size and weight reductions for light to medium duty applications with slow or intermittent rotation.

Given the fact that these bearings will most likely be used in lightly loaded applications where saving weight and space are the main objective, the loading values shown assume that the shaft and housing will also be of light construction. This will allow for greater bearing ring movement under load than traditional heavy section bearings. Thus the *loading limits* for capacity are not based on ABMA standards.

Depending on the support provided by the shaft and housing, this movement can create increased stress levels within the bearing. Distortion of the shaft and housing under load will transfer to the bearing, causing increased stress levels which could lead to premature failure and/or erratic torque conditions.

The impact of non-uniform shaft and housing distortions is best found by testing. If problems are experienced, increased rigidity of the shaft and housing may be necessary. If the shaft and housing are of sufficient rigidity, it may be possible for the bearings to support greater loads than the loading limits provided.

ULTRA-SLIM™ Bearing Selection Data

Angular Contact Type A									
KAYDON Bearing Number	Dimensions in mm				Capacity		Loading Limits		Mass in Grams
	Bore	Outside Diameter	Land Dia. L ₁	Land Dia. L ₂	Radial Newtons		Thrust Newtons ^③		
					Static ^①	Dyn. ^②			
*S03503ASO	35	41	37.2	38.8	382	383	1334	5	
*S06003ASO	60	66	62.2	63.8	649	552	1112	9	
*S07003ASO	70	76	72.2	73.8	756	609	1068	11	
*S07403ASO	74	80	76.2	77.8	799	632	1045	11	
*S08003ASO	80	86	82.2	83.8	863	663	1001	12	
*S09003ASO	90	96	92.2	93.8	970	716	956	13	
*S10003ASO	100	106	102.2	103.8	1077	765	890	15	
*S11003ASO	110	116	112.2	113.8	1183	814	867	16	
*S12003ASO	120	126	122.2	123.8	1290	863	823	18	
*S13003ASO	130	136	132.2	133.8	1407	912	778	19	
*S14003ASO	140	146	142.2	143.8	1514	956	734	21	
*S15003ASO	150	156	152.2	153.8	1621	1001	712	22	
*S16003ASO	160	166	162.2	163.8	1727	1045	689	24	
*S17003ASO	170	176	172.2	173.8	1834	1085	667	25	

Full complement or ball spacer ball 1/16" (inch)

④ F = 0.25
Bearing corners are normally chamfered

Radial Contact Type C								
KAYDON Bearing Number	Dimensions in mm				Capacity		Mass in Grams	
	Bore	Outside Diameter	Land Dia. L ₁	Land Dia. L ₂	Radial Newtons			
					Static ^①	Dynamic ^②		
*S03503CSO	35	41	37.2	38.8	418	418	5	
*S06003CSO	60	66	62.2	63.8	711	605	9	
*S07003CSO	70	76	72.2	73.8	827	667	11	
*S07403CSO	74	80	76.2	77.8	875	689	11	
*S08003CSO	80	86	82.2	83.8	944	725	12	
*S09003CSO	90	96	92.2	93.8	1062	783	13	
*S10003CSO	100	106	102.2	103.8	1178	841	15	
*S11003CSO	110	116	112.2	113.8	1295	894	16	
*S12003CSO	120	126	122.2	123.8	1412	943	18	
*S13003CSO	130	136	132.2	133.8	1540	1001	19	
*S14003CSO	140	146	142.2	143.8	1658	1050	21	
*S15003CSO	150	156	152.2	153.8	1774	1099	22	
*S16003CSO	160	166	162.2	163.8	1891	1143	24	
*S17003CSO	170	176	172.2	173.8	2006	1192	25	

Full complement or ball spacer ball 1/16" (inch)

④ F = 0.25
Bearing corners are normally chamfered

4-Point Contact Type X									
KAYDON Bearing Number	Dimensions in mm				Capacity		Loading Limits		Mass in Grams
	Bore	Outside Diameter	Land Dia. L ₁	Land Dia. L ₂	Radial Newtons		Thrust Newtons ^③	Moment Nm ^③	
					Static ^①	Dyn. ^②			
*S03503XS0	35	41	37.2	38.8	711	585	1045	7.9	5
*S06003XS0	60	66	62.2	63.8	1208	847	934	11.8	9
*S07003XS0	70	76	72.2	73.8	1407	934	890	13.0	11
*S07403XS0	74	80	76.2	77.8	1487	965	867	13.4	11
*S08003XS0	80	86	82.2	83.8	1606	1015	845	14.0	12
*S09003XS0	90	96	92.2	93.8	1805	1096	801	14.9	13
*S10003XS0	100	106	102.2	103.8	2003	1177	756	15.6	15
*S11003XS0	110	116	112.2	113.8	2201	1252	734	16.6	16
*S12003XS0	120	126	122.2	123.8	2400	1320	689	17.0	18
*S13003XS0	130	136	132.2	133.8	2618	1401	645	17.2	19
*S14003XS0	140	146	142.2	143.8	2818	1470	623	17.8	21
*S15003XS0	150	156	152.2	153.8	3016	1538	601	18.4	22
*S16003XS0	160	166	162.2	163.8	3215	1600	578	18.9	24
*S17003XS0	170	176	172.2	173.8	3413	1669	556	19.2	25

Full complement or ball spacer ball 1/16" (inch)

④ F = 0.25
Bearing corners are normally chamfered

① Static radial capacities are based on maximum allowable contact stresses. Adequate support of the races is assumed to help assure uniform ball support.
 ② Dynamic radial capacities are included for life calculation purposes. These are based on the assumption that the shaft and housing have adequate strength to support the loads without causing excessive distortion of the bearing rings.
 ③ Higher loading limits may be achieved with sufficiently rigid supports that will better restrict the movement of the bearing races under load.
 ④ Corner size is the maximum shaft or housing fillet radius that the bearing corners will clear.
 *Contact KAYDON for lead time and minimum purchase requirement.